

TM 9-6650-222-35

DEPARTMENT OF THE ARMY TECHNICAL MANUAL

DS, GS, AND DEPOT MAINTENANCE MANUAL
INCLUDING REPAIR PARTS AND
SPECIAL TOOL LISTS
FOR
PERISCOPE, TANK: XM48
(6650-762-9336)



HEADQUARTERS, DEPARTMENT OF THE ARMY

1966

CHANGE

No. 1

HEADQUARTERS,
DEPARTMENT OF THE ARMY
Washington, D.C., 24 August 1971

Depot Maintenance Manual Including
Repair Parts and Special Tools List
For
PERISCOPE, TANK: M48
(6650-762-9336)

TM 9-6650-222-35, 11 April 1966, is changed as follows:

1. The title is changed to read as shown above.
2. Change Periscope XM48 to read "Periscope M48" throughout the manual.
3. Remove old pages and insert new pages as indicated below.
4. New or changed material is indicated by a vertical bar in the margin of the page.
5. Added or revised illustrations are indicated by a vertical bar adjacent to the WE number.

Remove pages

1-1 through 1-4
1-7 and 1-8
4-1 and 4-2
5-1 through 5-6
5-9 and 5-10
B-3 through B-6
B-9 through B-11

Insert pages

1-1 through 1-4
1-7 and 1-8
4-1 and 4-2
5-1 through 5-6
5-9 and 5-10
B-3 through B-6
B-9 through B-11

6. File this change sheet in front of the publication for reference purposes.

TECHNICAL MANUAL }
 No. 9-6650-222-35 }

HEADQUARTERS,
 DEPARTMENT OF THE ARMY
 WASHINGTON, D. C. 20315, 11 April 1966

PERISCOPE, TANK: XM48
 (6650-762-9336)

	Paragraph	Page
CHAPTER 1. INTRODUCTION		
Section I. General.....	1-1	1-1
II. Description and data.....	1-5	1-1
CHAPTER 2. TOOLS AND EQUIPMENT.....	2-1	2-1
CHAPTER 3. INSPECTION		
Section I. General.....	3-1	3-1
II. Inspection in the using position.....	3-3	3-1
III. Shop inspection	3-9	3-2
CHAPTER 4. TROUBLESHOOTING		
Section I. General.....	4-1	4-1
II. Troubleshooting procedures.....	4-3	4-1
CHAPTER 5. REPAIR		
Section I. General.....	5-1	5-1
II. Repair.....	5-6	5-1
CHAPTER 6. EQUIPMENT ISSUED WITH PERISCOPE XM48		
Section I. Description.....	6-1	6-1
II. Repair of headrest assembly.....	6-3	6-2
CHAPTER 7. PROCESSING AND PACKAGING.....	7-1	7-1
APPENDIX I. REFERENCES.....		A-1
II. REPAIR PARTS AND SPECIAL TOOL LISTS.....		B-1
INDEX		I-1

CHAPTER 1

INTRODUCTION

Section I. GENERAL

1-1. Scope

a. This publication contains instructions for the repair of tank periscope M48, 6650-762-9336, and associated equipment, by direct support (DS¼ general support (GS), and depot shops.

Note. Refer to DMWR 9-6650-222 for overhaul/reconditioning instructions for the Periscope M48. Requests for DMWR 9-6650-222 in support of approved overhaul /reconditioning programs shall be forwarded to Commanding Officer, Frankford Arsenal, ATTN: AMSWE-MAF-W3100, Philadelphia, Pa. 19137.

b. These instructions are used in conjunction with and are supplementary to those in the operator's and organizational maintenance manual for armored reconnaissance-airborne assault vehicle M55a. Instructions for operation, lubrication, and operator's maintenance (including installation and removal procedures, as well as tests and adjustments after installation) are contained in TM 9-2350-230-12. It may be necessary to refer to this

manual for complete procedures.

1-2. Comments

Report errors, omissions, and recommendations directly to Commanding Officer, Frankford Arsenal, ATTN: AMSWE-MAF-W3100, Philadelphia, Pa. 19137 on DA Form 2028.

1-3. Maintenance Allocation and Parts

The maintenance allocation chart in TM 9-2350-230-12 and repair parts and tools listed in appendix II allocates maintenance responsibilities.

1-4. Forms, Records, and Reports

a. *Authorized Forms.* The forms are listed in DA Pamphlet 310-2 and TM 38-750.

b. *Report of Accidents.* The necessary reports are prescribed in AR 385-40.

c. *Equipment Improvement Recommendations (EIR).* Use the Equipment Improvement Recommendation section of DA Form 2407.

Section II. DESCRIPTION AND DATA

1-5. Description

a. *General.* Periscope M48 (figs. 1-1 and 1-2) is an infrared, unity-power binocular periscope that provides a 41-1/2 degree field-of-view. The periscope is primarily intended for use in conjunction with two infrared headlights as the driver's night viewing system in the M551 vehicle. Operating instructions and a functional description of periscope are provided in utm 9-2350-230-12.

b. *Optical Scheme.* The periscope optical scheme (fig. 1-3) consists of a prism in the head assembly which deflects the field-of-view downward through

a vertical lens system to a prism in the body assembly; this prism further deflects the field-of-view through a horizontal lens system and image converter electron tubes to a binocular eyepiece viewing assembly.

c. *Head Assembly 6650-906-7941.*

(1) Head assembly 6650-906-7941 contains prism 8599693 (fig. 1-1) which is mounted in the head and sealed against water penetration. The bottom of the head is open but is provided with a gasket for sealing when joined with body assembly 10513599.

(2) Two mounting holes are provided on the head for engaging the plungers of mount assembly 6650-906-7944. Mount assembly is required for assembling head assembly to body assembling 10513599.

d. Body Assembly 10513599.

(1) Body assembly 10513599 is a nitrogen gas filled, sealed unit that receives the reflected line of sight from head assembly 6650-906-7941. In-addition, body assembly 10513599 also houses electrical and electronic components for control of the infrared converter system.

(2) Two catches (fig. 1-1) engage corresponding strikes on mount assembly when mounting body assembly 10513599. An identification plate for periscope M48 is mounted on body assembly 10513599 and contains the serial number of the unit.

(3) Valve assembly 8201751 is located on the side of body assembly 10513599 and is used for purging and charging the unit with nitrogen gas.

(4) A compartment in body assembly 10513599 houses power supply 1240-077-1688 (fig. 1-4) and either the converter 1240-878-7768 or the 1.5 volt, C-size dry battery 6135-120-1010. These latter two items are interchangeable by removing cap

assembly 8589920 (fig. 1-1). This arrangement permits the use of externally supplied 24-volt dc, or 1.5-volt dc supplied by the dry battery. Switch 5930-925-3631 (fig. 1-1) on body assembly 10513-599 is provided to control the mode of operation used. Schematic representation of the two modes of operation are illustrated in figure 1-5.

1-6. Data

a. Optical Characteristics.

Power	1.00x
Field-of-View	41-1/2 degree
Effective focal length (objective).	1.323
Effective focal length (eyepiece).	1.020
Magnification of image tube.	0.77 x
Eyepiece setting	-0.50 to -1.0 diopters

b. Weight.

Head assembly	5.5 lb
Body assembly	11.1 lb
Mounting plate assembly	8.6 lb

c. Size.

Width	10.125 in.
Overall height.	9.625 in.9.625 in.
Maximum depth	7.125 in.

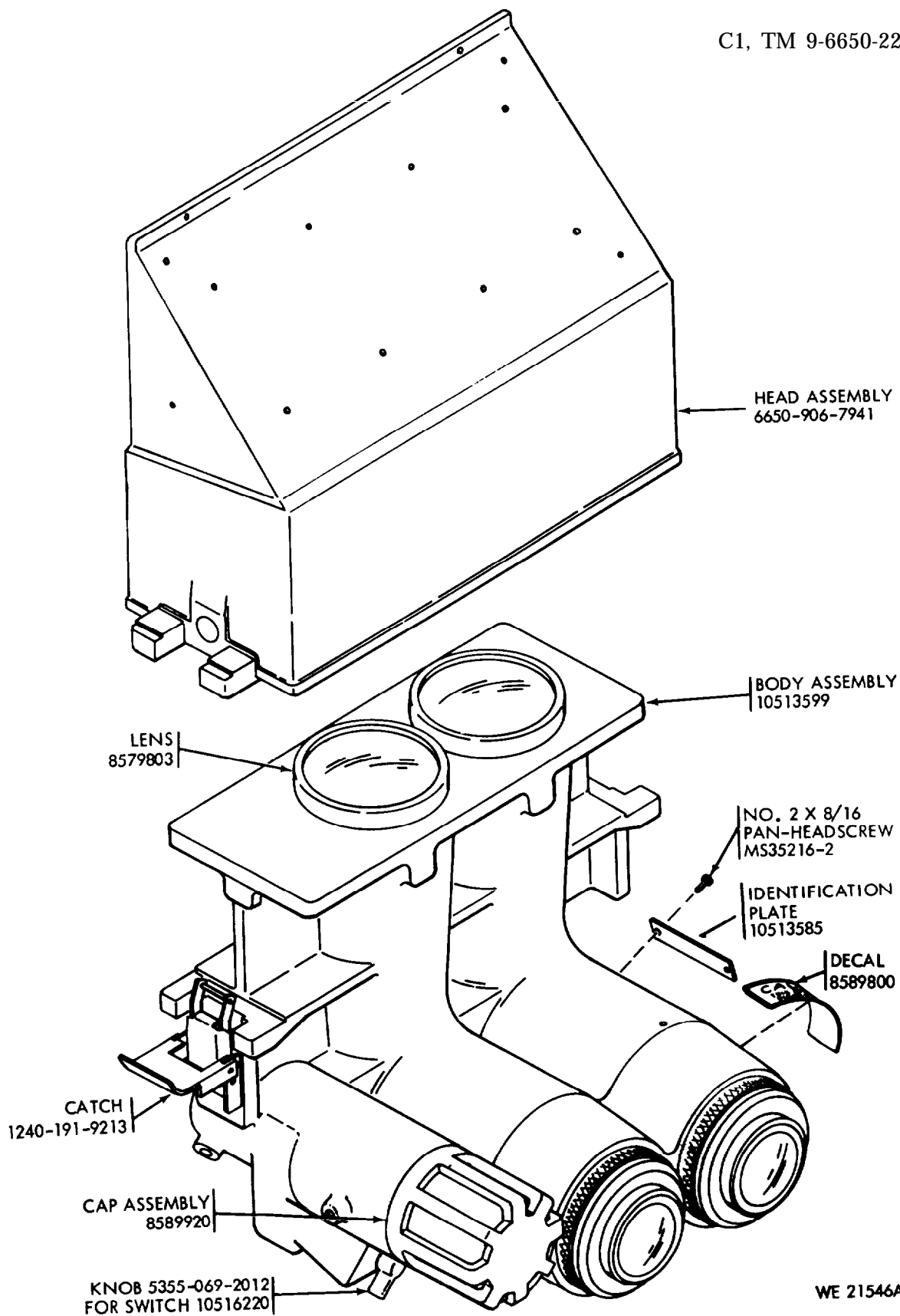
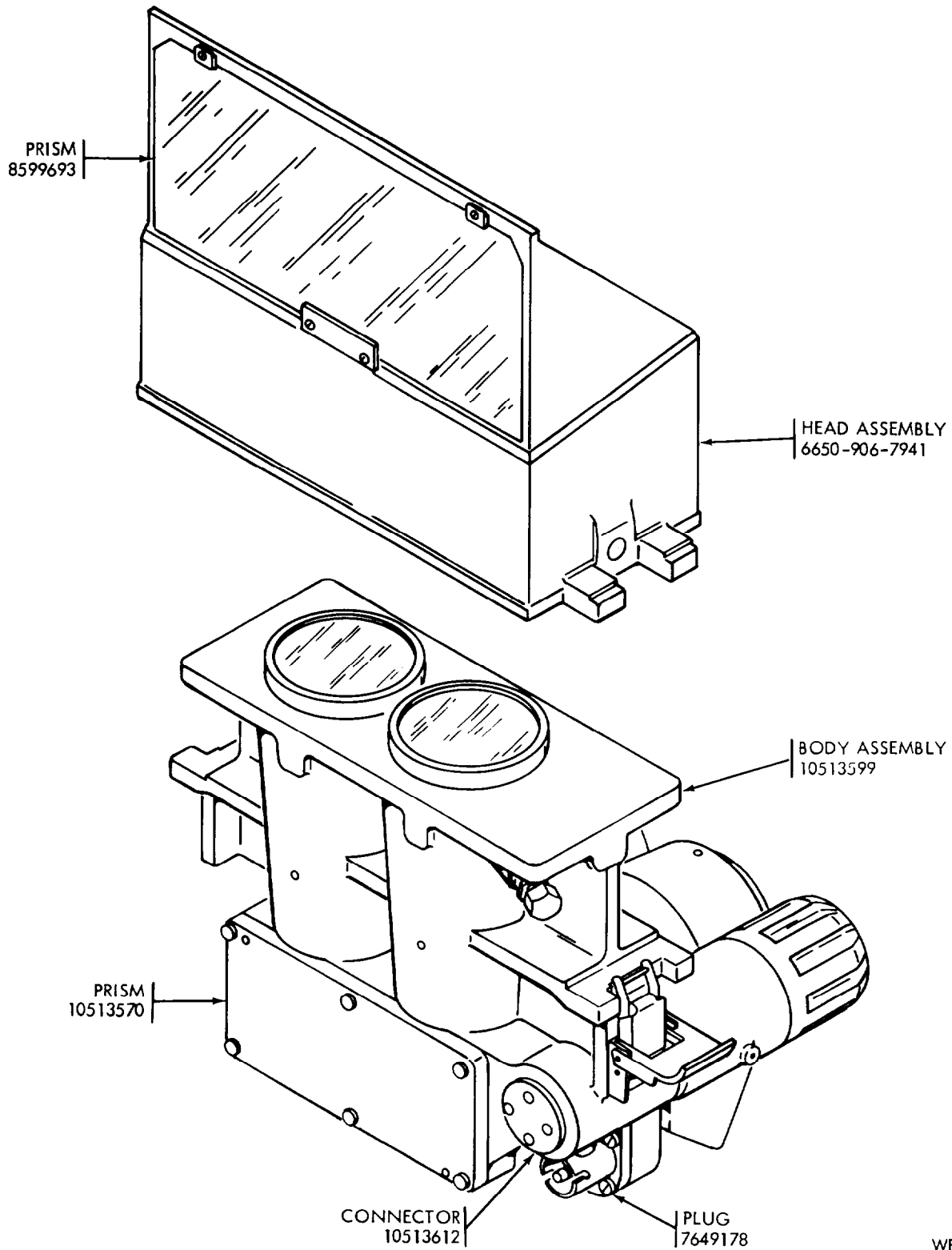

Figure 1-1. Periscope, tank M48, 6650-762-9936.



WE 21547

Figure 1-1. Periscope, tank. M48, 6650-762-9336.

Figure 1-2
has yet to be digitized.
Please refer to your paper or
microfiche copy as appropriate.

NOT DIGITIZED

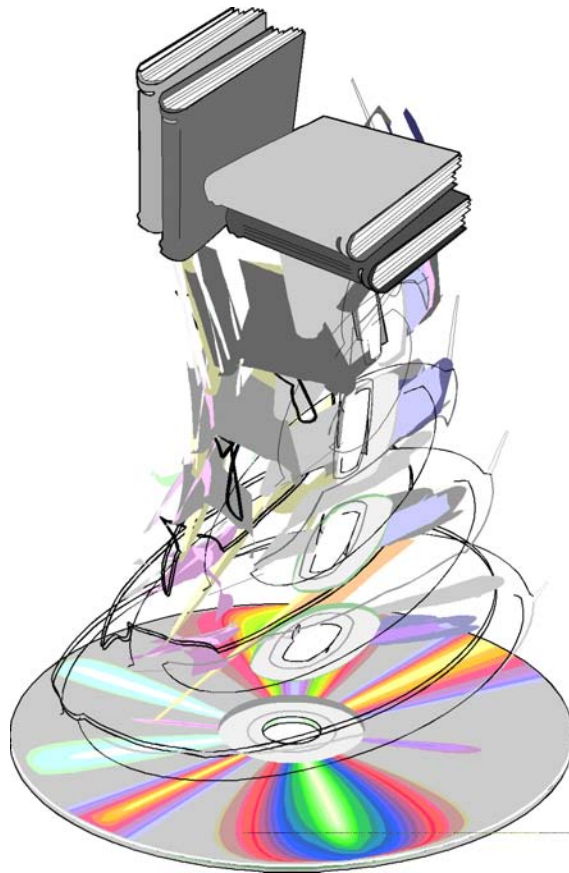

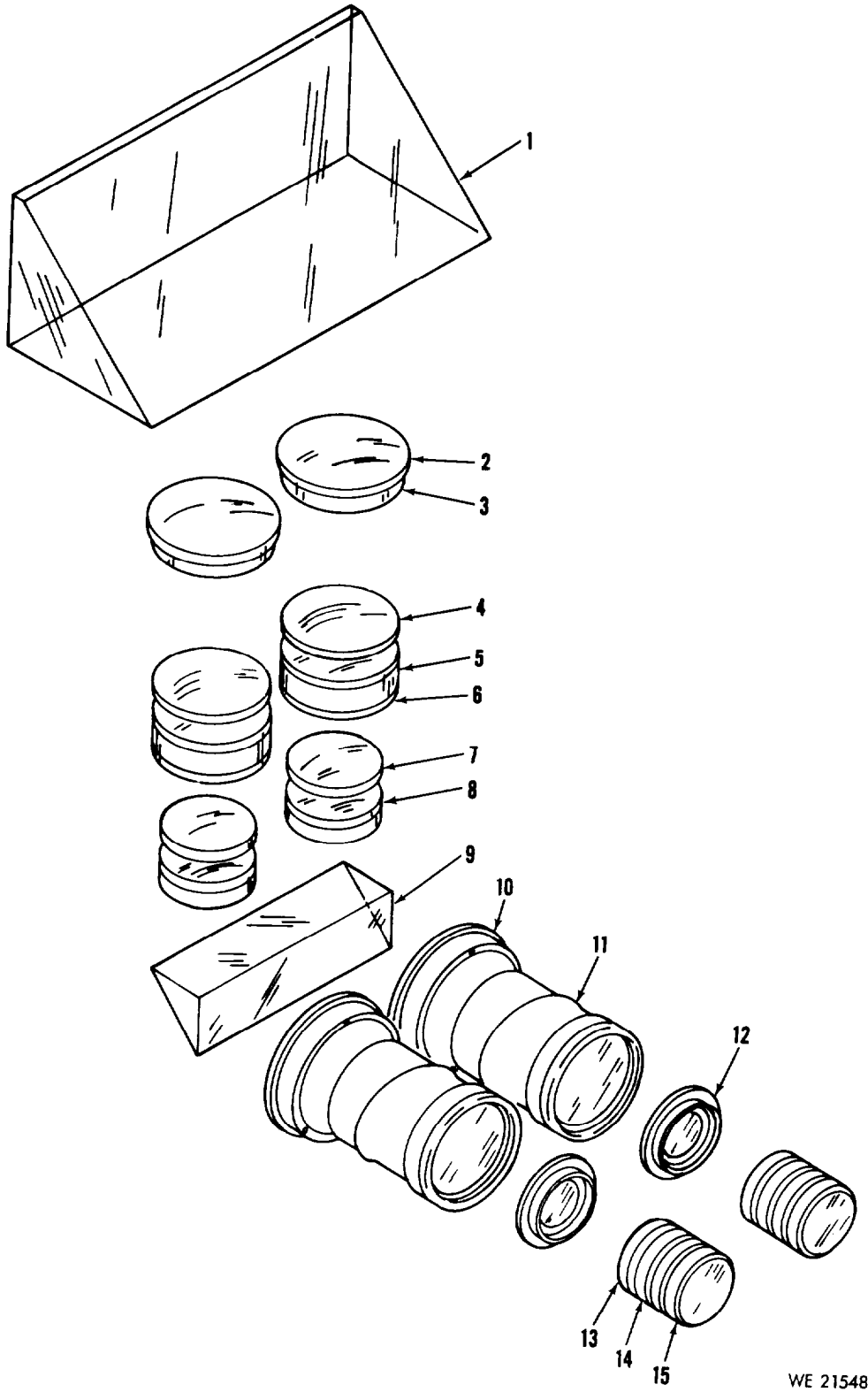

Figure 1-3. Periscope, XM48-optical diagram.

WE 21548

- 1-Prism 8599693 (Aperture = 7.210 X 3.125)
- 2-Lens 6650-904-4570 (2) (Aperture = Entrance = 1.192, Exit = 1.70)
- 3-Lens 6650-902-9736 (2) (Aperture = 1.72)
- 4-Lens 6650-902-9737 (2) (Aperture = 1.29)
- 5-Lens 1240-W-8725 (2) (Aperture = 1.29)
- 6-Filter 1240-768-8724 (2) (Aperture = 1.29)
- 7-Lens 1240-768-8722 (2) (Aperture = 0.944)
- (For this instrument, R1 & R2 are reversed)
- 8-Lens 1240-768-8718 (2) (Aperture = 0.944)

- 9-Prism 10513551 (Aperture = 0.869)
- 10-Lens 8579814 (2) (Aperture = 1.000)
- 11-Image Converter Tube, Electron (2) 5960-082-3326
- 12-Lens 10514278 (2) (Aperture = 0.827)
- 13-Lens 6650-903-7225 (2) (Aperture = Entrance 0.969, Exit = 1.133)
- 14-Lens 6650-902-9739 (2) (Aperture = 1.166)
- 15-Lens 6650-902-9740 (2) (Aperture = Entrance 1.088, Exit = 0.967)

Figure 1-3 - Continued.

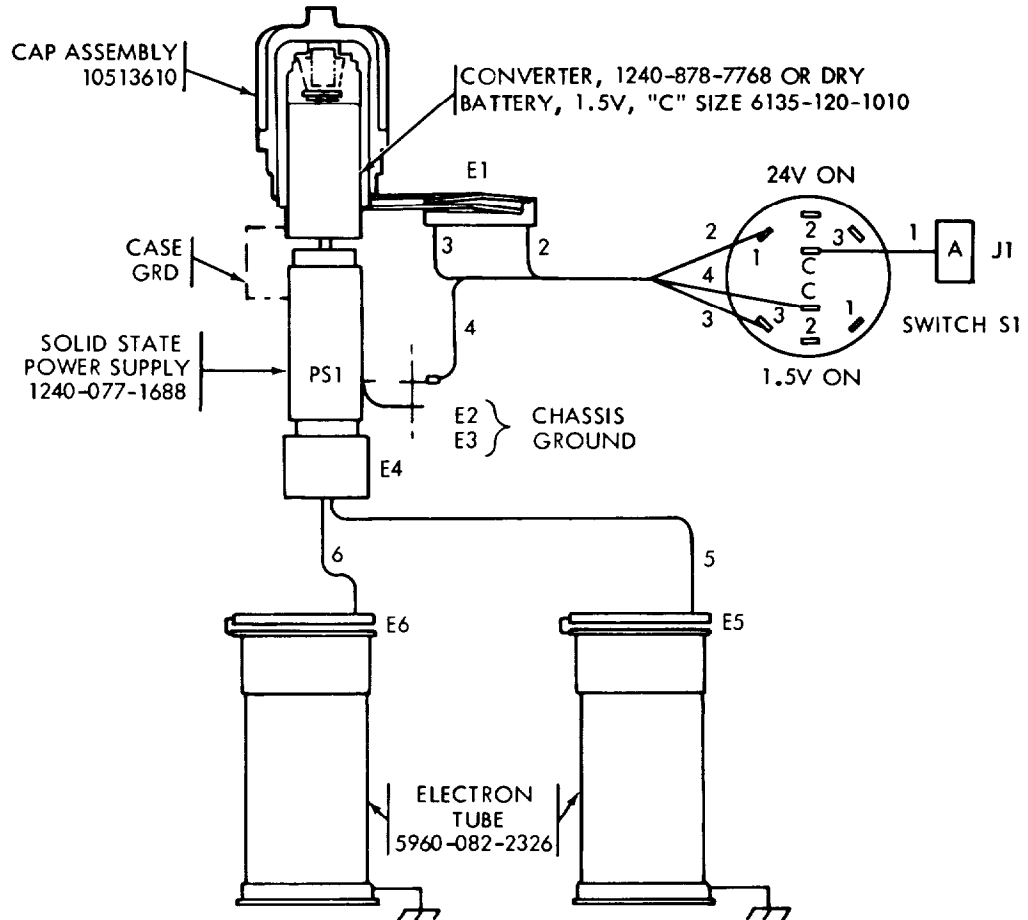

NOTE: CASE GROUND SHOWN IN DOTTED LINE APPLIES ONLY WHEN THE CONVERTER IS INSTALLED.

WE 21549A

Figure 1-4. Periscope M48-wiring diagram.

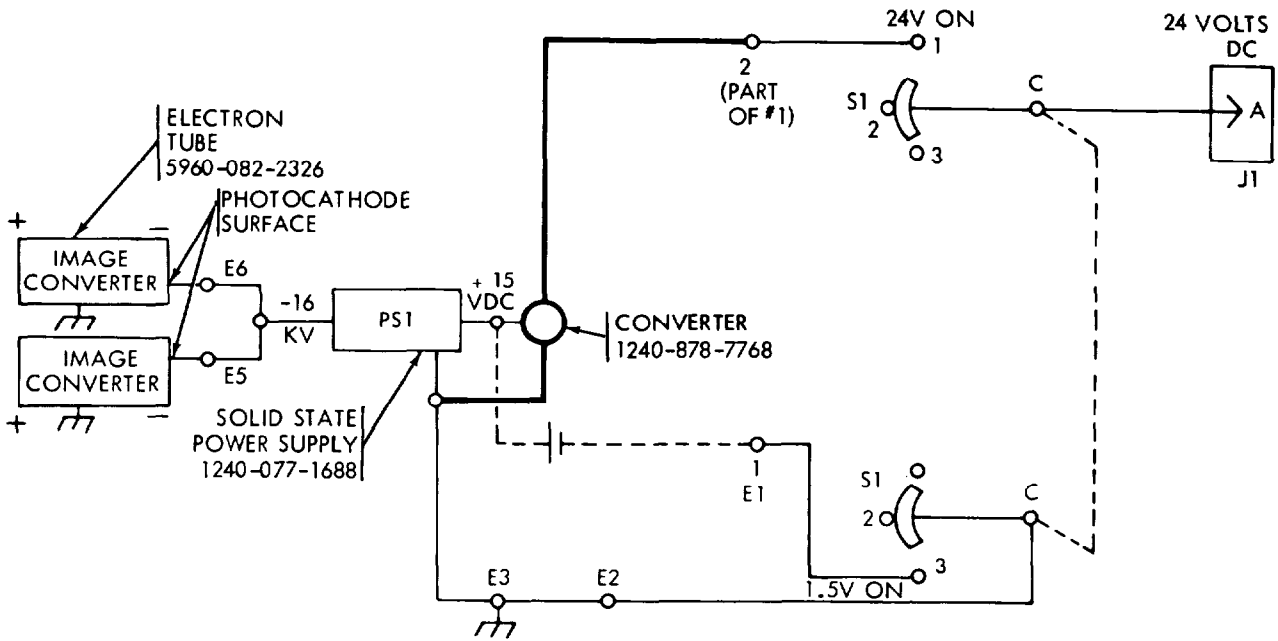

NOTE: WIRING SHOWN IN DOTTED LINES SHOWS CONNECTIONS WHEN DRY BATTERY IS USED. WIRING SHOWN IN HEAVY LINES SHOWS CONNECTIONS WHEN CONVERTER IS USED.

WE 21550A

Figure 1-5. Periscope M48-schematic diagram.

CHAPTER 2
TOOLS AND EQUIPMENT

2-1. Common Tools and Equipment

Standard and commonly used tools and equipment having general application to this materiel are authorized for issue by TA and TOE.

2-2. Special Tools and Equipment

Table 2-1 lists the special tools and equipment which are necessary to perform the operations described in this manual. Special tool sets of a general nature are authorized by TA and TOE. Special tools peculiar to this equipment are authorized in appendix II.

Table 2-1. Special Tools and Equipment

Nomenclature	Federal stock No.	Part No.	References		
			Fig.	Para	
ADAPTER, NITROGEN FILLING:	4931-508-5453	7680682	5-15	5-13	Connects regulator 1240-558-0922 to nitrogen tank.
SEALING COMPOUND GUN, HYDAULIC: injection	4931-508-5428	6721501		5-8e	Used for injecting non-curing sealing compound Type I, Class I, MIL-S-11030.
HOSE, assembly:	4931-508-5546	8572413	5-15	5-13	Used with test gage assembly 4931-546-9773.
HOSE, ASSEMBLY, RUBBER:	4931-561-0713	8572414	5-15	5-13	Connects regulator 1240-558-0922 to periscope XM48.
REGULATOR, HELIUM, PRESSURE:		5580922	5-15	5-13	Used to control the flow of nitrogen during purging and charging operations.
TANK, NITROGEN,:	6830-264-9086		5-15	5-13	Container with dry nitrogen gas used in purging and charging operations.
TEST GAGE: ASSEMBLY	4931-546-9773	8572412	5-15	5-13	Used with hose assembly 4931-508-5546 to check internal pressure during purging and charging operations.

CHAPTER 3

INSPECTION

Section I. GENERAL

3-1. Scope

This chapter sets forth inspection of periscope XM48 in the using position and in maintenance shops.

3-2. Purpose

Inspection is performed primarily, (1) to determine completeness, (2) to determine the

nature of unserviceability, (3) to determine the work, repair parts, and supplies required to return the materiel to serviceability, (4) to ensure that work in process is being performed properly, and (5) to ensure that completed work complies fully with serviceability standards.

Section II. INSPECTION IN THE USING POSITION

3-3. General

In general, the periscope will be considered serviceable if it is complete and all deficiencies have been corrected ensuring operation in accordance with serviceability standards.

3-4. Using Position

Inspection in the using position refers to the inspection performed by maintenance personnel when the periscope is mounted on the XM551 vehicle, Inspection of periscope removed from the end item is set forth in paragraphs 3-9 through 3-12.

3-5. Modification Work Orders (MWO)

All applicable modification work orders will be applied. DA Pamphlet 310-4 contains the MWO index and equipment records DA Form 2408-5 or DA Form 2409 list MWO's applied.

3-6. General Inspection

a. Note the general appearance of the periscope to determine the type of treatment it has received.

b. Check the exterior of the periscope for dented surfaces, bent, broken or missing catches or other parts, moisture or corrosion, and other evidence of damage or misuse which might indicate a need for repair.

c. Inspect the sealed areas around housing 10513565, lens 6650-904-4570, prism 1240-907-6.512, plug 8620049, metal junctions, and all visible external screws.

d. Inspect lettering on identification plate for legibility.

e. Inspect for bare spots or damaged finish which expose metal surfaces and lead to corrosion.

f. Inspect the two catches on the body assembly to make sure they operate smoothly without binding or rough motion, and that they properly engage the head assembly.

g. Check the valve assembly to ensure that the valve cap is on and tight and that the stem is not bent.

h. Make sure the equipment is free from dirt and grit.

i. Refer to the Basic Issue Items List in TM 9-2350-230-12 and check for completeness of repair parts, tools, and equipment.

3-7. Inspection of Optical Components

Note. Optical instruments will not be rejected for conditions which can be detected only by the shading or shadowing technique. When viewing through the eyepiece of the instrument, only those defects which are apparent when the instrument is used in a manner simulating field conditions will be cause for rejection. Shadowing is the technique of looking into the eyepiece or objective of an instrument obliquely so as to obtain reflections from a particular surface in the optical system. With this method the surfaces of lenses are dark grey in appearance and all defects, such as condensate, scratches, etc. show up as white particles.

Note. Due to irregularities in the fluorescent screen of the image converter tubes, hot or cold spots will appear as dark or light spots. The hot or cold spots are not to be considered dirt. To differentiate between these spots and dirt, decrease the power supply voltage and the irregularities will change from dark to light or light to dark spots, while dirt on the optical surfaces remains dark.

a. The presence of dirt, lint, scratches and/or digs will be cause for rejection only to the

extent that they significantly impair the ability to observe the field-of-view.

b. When looking directly through the eyepiece of the body assembly there will be no evidence of moisture or fungus growth.

c. Polished optical surface shall show no evidence of grayness or stain.

d. Eyepiece focus shall be set between the limits of -0.5 and -1.0 diopter.

e. The image will be sharp and clear at the center of field.

3-8. Inspection of Electrical Components

a. Inspect switch 10516220 to see that the knob is tight on the shaft and that the action of the switch is firm. Make sure the switch mounting screws are tight and hold the switch firmly in position.

b. Inspect plug 1290-764-9178 for damage and to see that it is tight and that a good electrical connection is made when the 24-volt external supply is plugged in.

Section III. SHOP INSPECTION

3-9. General

This section sets forth the procedure to be followed by maintenance shops in performing inspection of periscope XM48 when removed from the end item and turned into the shop for repair.

3-10. Initial Inspection

The general inspection procedures outlined in paragraphs 3-3 through 3-8 should be followed when periscope XM48 is initially received in the shop.

3-11. Sealing

Determine integrity of seals with soap and water solution as specified in paragraph 5-13a.(10).

3-12. Inspection of Optical Components

a. *Head Assembly.* When looking through the head assembly of the periscope there shall be no objectionable dirt smears, scratches, digs, condensate or fungus growth. Chips and fractures are permitted provided they are stoned or ground and do not extend more than 1/4-inch beyond the clear aperture. In all cases prime emphasis should be placed on performance of the periscope rather than the optical appearance, unless the latter definitely indicates poor workmanship.

b. *Body Assembly.* When looking directly through the eyepiece of the body assembly, cement separations extending more than 1/4-inch from the edge of the clear aperture will not be acceptable.

CHAPTER 4 TROUBLESHOOTING

Section I. GENERAL

4-1. Purpose

Troubleshooting is a systematic isolation and remedy of malfunctions and defective components by means of symptoms and tests. Close adherence to the procedures covered herein will materially reduce the time required to locate trouble and restore the equipment to normal operation.

Caution: Operation of materiel without a pre-

liminary examination can cause further damage to a faulty component. Exercise care during troubleshooting, to avoid further damage.

4-2. General

For troubleshooting procedures performed by organizational maintenance, refer to TM 9-2350-230-12.

Section II. TROUBLESHOOTING

4-3. General

The troubleshooting procedure described in this section is one of determining the cause of the malfunction and taking the necessary corrective action.

4-4. Troubleshooting

Table 4-1 describes the troubleshooting procedure.

Table 4-1. Troubleshooting

Malfunction	Probable cause	Corrective action	Lowest maintenance category
1. Poor field-of-view.	a. Cracked or damaged lens, prism, or filter in binocular tube of head assembly 10513599.	a. Disassemble and inspect the optical components of head assembly 10513599.	Depot
	b. Faulty image converter electron tube 5960-082-3326 (3, fig. 5-8).	b. Replace image converter electron tube 5960-082-3326.	DS
	c. Condensation on internal lens. 5-13).	c. Purge charge and body assembly 10513599, para <i>Note.</i> See also trouble 2 below since lack of nitrogen gas may be the result of a leaking seal.	DS
2. Pressure cannot be maintained in body assembly 10513599.	a. Defective valve assembly 8201751 (4, fig. 5-2).	a. Disassemble and repair valve assembly 8201751 para 5-8).	DS
	b. Faulty machine thread plug 5365-684-4401 (5, fig. 5-2) or gasket 5330-683-9573 (6, fig. 5-2).	b. Replace machine thread plug or gasket (para 5-9).	DS
	c. Faulty preformed packing (3, fig. 5-13) around housing 10513625.	c. Replace faulty preformed packing	Depot

Table 4-1. Troubleshooting-Continued

Malfunction	Probable cause	Corrective action	Lowest maintenance category
2. Pressure cannot be maintained in body assembly 10513599-Continued	<ul style="list-style-type: none"> d. Faulty preformed packing (2A, fig. 5-8) around cell assembly 10513580. 	<ul style="list-style-type: none"> d. Replace faulty preformed packing. 	Depot
	<ul style="list-style-type: none"> e. Faulty sealing around prism 1240-907-6512 (3, fig. 5-5). 	<ul style="list-style-type: none"> e. Remove, reseal, and replace prism. 	Depot
	<ul style="list-style-type: none"> f. Faulty sealing around plug 8589801 (3, fig. 5-6). 	<ul style="list-style-type: none"> f. Remove, reseal, and replace plug. 	DS
	<ul style="list-style-type: none"> g. Faulty gasket 5330-912-4893 (4, fig. 5-4). 	<ul style="list-style-type: none"> g. Replace gasket 5330-912-4852 	DS
	<ul style="list-style-type: none"> h. Cracked head or other major repair item. 	<ul style="list-style-type: none"> h. Overhaul body assembly 10513599. 	Depot
3. Head assembly or body assembly out of alignment or loose when installed.	<ul style="list-style-type: none"> a. Faulty catch(es) 1240-191-9213 (3, fig. 5-2) 	<ul style="list-style-type: none"> a. Replace catch(es) 1240-191-9213 (para 5-7). 	DS
	<ul style="list-style-type: none"> b. Damaged or worn gasket (6, fig. 5-1 of head assembly 6650-906-7941. 	<ul style="list-style-type: none"> b. Replace gasket. 	DS
4. Periscope does not function when switch 5930-925-3631 is turned on.	<ul style="list-style-type: none"> a. External 24-volt dc not properly connected. 	<ul style="list-style-type: none"> a. Check that power is properly connected and turned on. 	o
	<ul style="list-style-type: none"> b. Loose or defective plug 1290-764-9178 (3J, fig. 	<ul style="list-style-type: none"> b. Tighten or replace plug 1290-764-9178. 	DS
	<ul style="list-style-type: none"> c. Defective switch 5930-925-3631 (9, fig. 5-3). 	<ul style="list-style-type: none"> c. Tighten or replace switch 5930-925-3631. 	DS
	<ul style="list-style-type: none"> d. Defective power supply 1240-077-1688 (5, fig. 5-7). 	<ul style="list-style-type: none"> d. Replace power supply 1240-077-1688 (para 5-11). 	DS
	<ul style="list-style-type: none"> e. Defective converter 1240-878-7768 (3, fig. 5-7). 	<ul style="list-style-type: none"> e. Replace converter 1240-878-7768 (para. 5-11). 	DS

CHAPTER 5 REPAIR

Section I. GENERAL

5-1. Scope

This chapter contains detailed instructions for the repair of periscope M48.

Note. This manual contains exploded-view illustrations which depict the complete disassembly of the materiel. This should not be construed as authority to disassemble materiel beyond that required to perform operations authorized on the MAC or to replace parts other than those authorized in the applicable columns in appendix II.

5-2. Parts Replacement

In subsequent repair paragraphs, replacement of authorized parts damaged beyond repair is understood.

5-3. General Maintenance Procedures

TM 9-254 presents general maintenance procedures that are most often required in repairing fire control materiel.

5-4. Rescinded

5-5. Cleaning

Refer to TM 9-208-1 for procedures most often required in cleaning fire control materiel.

Section II. REPAIR

5-6. General

The paragraphs that follow set forth the procedures to replace authorized repair parts and to perform purely maintenance operations not involving repair parts replacement. Refer to appendix II for a list of authorized repair parts.

5-7. Replacement of Catch 1240-191-9213

a. Removal. Disassemble items 1, 2, and 3 (fig. 5-2).

b. Inspection.

(1) Inspect the hinge pin and the latching member for proper alinement.

(2) Inspect the mounting surface of the catch for burrs, dirt, or any condition that could prevent proper seating of the catch when it is installed.

(3) Inspect the surface of the body assembly where the catch is mounted for any item that could

prevent proper mounting and alinement of the catch.

c. Installation. Assemble in sequence items 3, 2, and 1 (fig. 5-2).

5-8. Repair of Valve Assembly 8201751

a. Removal. Remove valve assembly (4, fig. 5-2).

b. Disassembly. Disassemble items in legend sequence (4, fig. 5-2).

c. Inspection. Inspect the parts of the valve assembly for obvious wear, deterioration and other signs of unserviceability. Pay particular attention to the condition of the valve and make sure it operates smoothly, is free of corrosion, and that the rubber seats are not worn. Inspect the valve stem and cap for worn threads and for burrs on the threads.

d. Assembly. Assemble in reverse legend sequence (4, fig. 5-2).

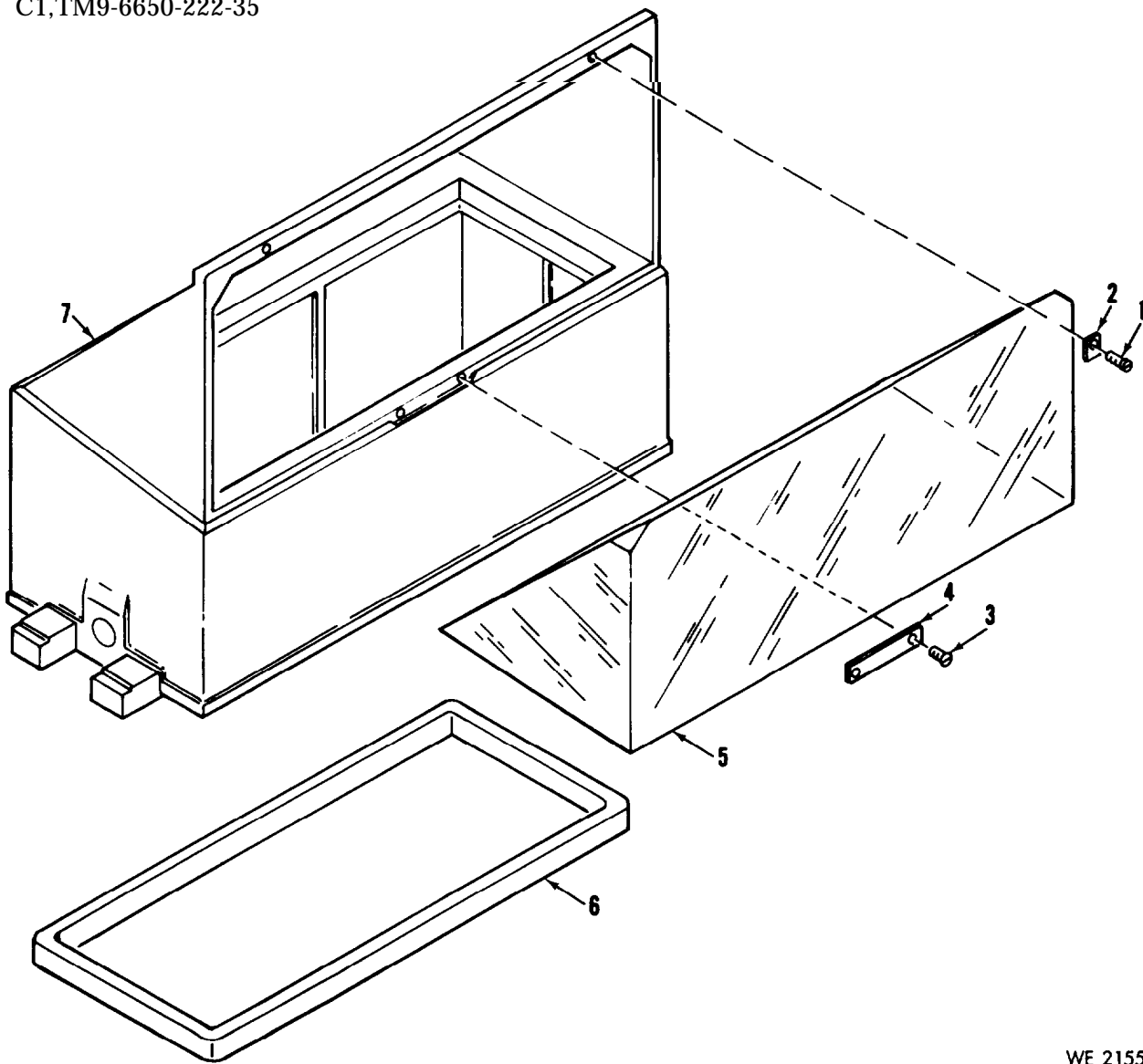

WE 21551

- 1—Screw, machine: pan hd, cross recess no. 6-32 UNC-2A, 1/4 lg (2) 5305-054-6650
- 2—Clip (2) 10513622-2
- 3—Screw, machine: pan hd, cross recess no. 6-32 UNC-2A, 1/4 lg (2) 5305-054-6650
- 4—Clip 10513628
- 5—Prism 8599693
- 6—Gasket 10513627
- 7—Head 10513626

Figure 5-1. Head assembly 6650-906-7941—exploded view

e. *Installation.* Carefully thread the valve assembly into the housing (fig. 5-2) applying sealing compound, MIL-S-11031, 8030-275-8110 to the threads of the stem. Tighten the valve assembly into position.

5-9. Replacement of Machine Thread Plug 5365-684-4401 and Gasket 5330-683-9573

a. *Removal.* Disassemble items 5 and 6 (fig. 5-2).

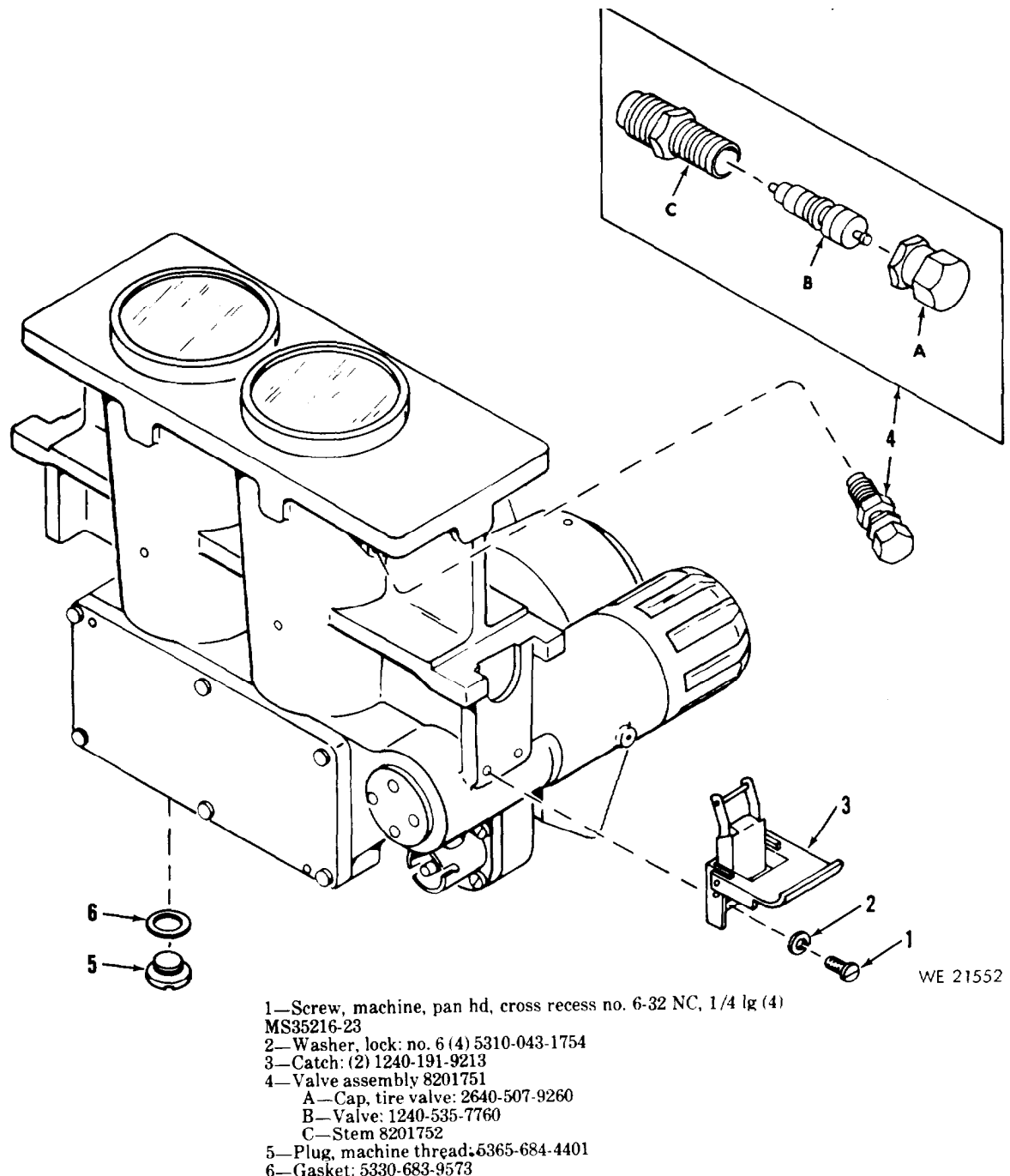

Figure 5-2 Exterior parts body assembly 10513599--partial exploded view.

b. Inspection.

(1) Inspect the machine thread plug for damaged threads, damaged screwdriver slot, and corrosion.

(2) Inspect the tapped hole of the body for damaged threads and the presence of any foreign

matter that could prevent proper seating of the plug.

(3) Inspect the gasket for breaks, damage, or deterioration that could prevent a good seal.

c. Installations. Assemble in sequence items 6 and 5 (fig. 5-2).

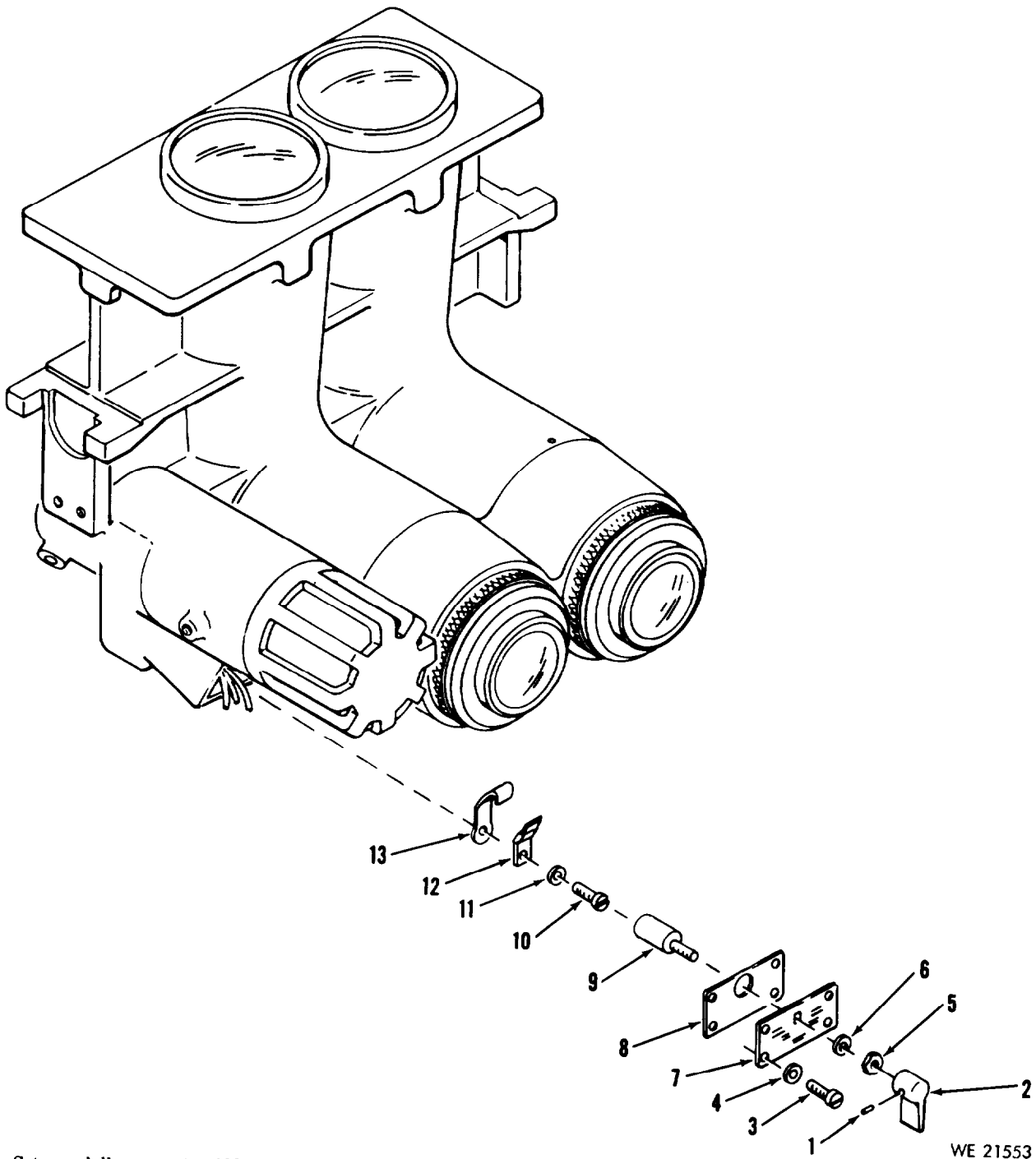

- 1—Setcrew: hdls soc no. 4-40 NC-3A, 0.125 lg (2) 5305-800-7261
- 2—Knob: 5355-069-2012
- 3—Screw, machine: pan hd, cross recess no. 6-32 UNC, 7/16 lg (4) 5305-054-6653
- 4—Washer, lock: no. 6 (4) 5310-043-1754
- 5—Nut (vendor's item furnished with item 9)
- 6—Washer (vendor's item furnished with item 9)

- 7—Plate 10516219
- 8—Gasket: 1240-069-2013
- 9—Switch, rotary: 5930-925-3631
- 10—Screw, machine: pan hd, cross recess no. 8-32 UNC, 7/16 lg 5305-054-6669
- 11—Washer, lock: no. 8 MS35333-72
- 12—Terminal, lug MS35430-5
- 13—Clip, spring tension: 5340-077-8727

WE 21553

Figure 5-3. Rotary switch 5930-925-3631 and related parts—partial exploded view.

5-10. Replacement of Rotary Switch 5930-925-3631

a. Removal.

- (1) Disassemble items 1 through 8 (fig. 5-3).
- (2) Unsolder connections to switch (9) and remove switch from body assembly.
- (3) Disassemble items 10 through 13.

b. Inspection.

- (1) Inspect the knob for breaks and corrosion.
- (2) Inspect the gasket for any breaks, damage or deterioration that could prevent a perfect seal.
- (3) Inspect the switch housing for dents, breaks, and corrosion.
- (4) Check the switch shaft for alinement, damaged threads, and firm, positive action.
- (5) Inspect the switch connections for breaks and excess solder.
- (6) Inspect the disconnected wires for broken insulation and excess solder.
- (7) Inspect the nut for corrosion, damaged threads and proper seating on the switch shaft.
- (8) Inspect the screw, washer, terminal, and spring for breaks, cracks and corrosion.
- (9) Inspect the screw for damaged threads. Check the tapped hole in the body assembly for damaged threads or the presence of any condition that could prevent proper seating of the screw.
- (10) Check the spring to see that tension is adequate to make a good electrical contact against the power supply.

- (11) Inspect the terminal for excess solder.

c. Installation.

- (1) Assemble in sequence items 13, 12, 11 and 10 (fig. 5-3) making sure that spring tension clip (13) makes contact with the case of solid state power supply 1240-077-1689.
- (2) Connect the wires to switch (9, fig. 5-3) in accordance with the wiring diagram (fig. 1-4).

- (3) Assemble in sequence items 9 through 1 (fig. 5-3), applying a small amount of sealing compound, MIL-S-11031, to the threads of item 1.

5-11. Replacement of Cap Assembly 6650-939-7174 and Power Supplies

a. Removal.

- (1) Disassemble items 1 through 6 (fig. 5-7).

Note. If dry battery 6135-120-1010 is installed instead of converter 1240-878-7768, the same removal procedure will apply except that the dry battery will be removed in place of the converter. The battery (if present) should not be replaced during assembly however, since it is only an emergency measure of power and should not replace the converter for normal operation.

- (2) Disassemble items 7 through 10.

b. Inspection.

- (1) Inspect the outside surface of the cap for dents, breaks, or corrosion.
- (2) Inspect the inside of the cap for broken springs.
- (3) Inspect the insulator for breaks and cracks.
- (4) Inspect the case and shield of converter 1240-878-7768 for cracks, corrosion, or other signs of deterioration.
- (5) Make sure the converter fits in the shield and cap assembly without binding.
- (6) Inspect the inside of the cap assembly for corrosion.
- (7) Inspect the springs for breaks and adequate resiliency.
- (8) Inspect the large spring to be sure it makes a good electrical contact with the end of the converter.
- (9) Inspect the case of solid state power supply 1240-077-1688 for cracks, corrosion, swelling, and any other signs of deterioration.
- (10) Check to see that the power supply fits properly (without binding) in the body assembly.

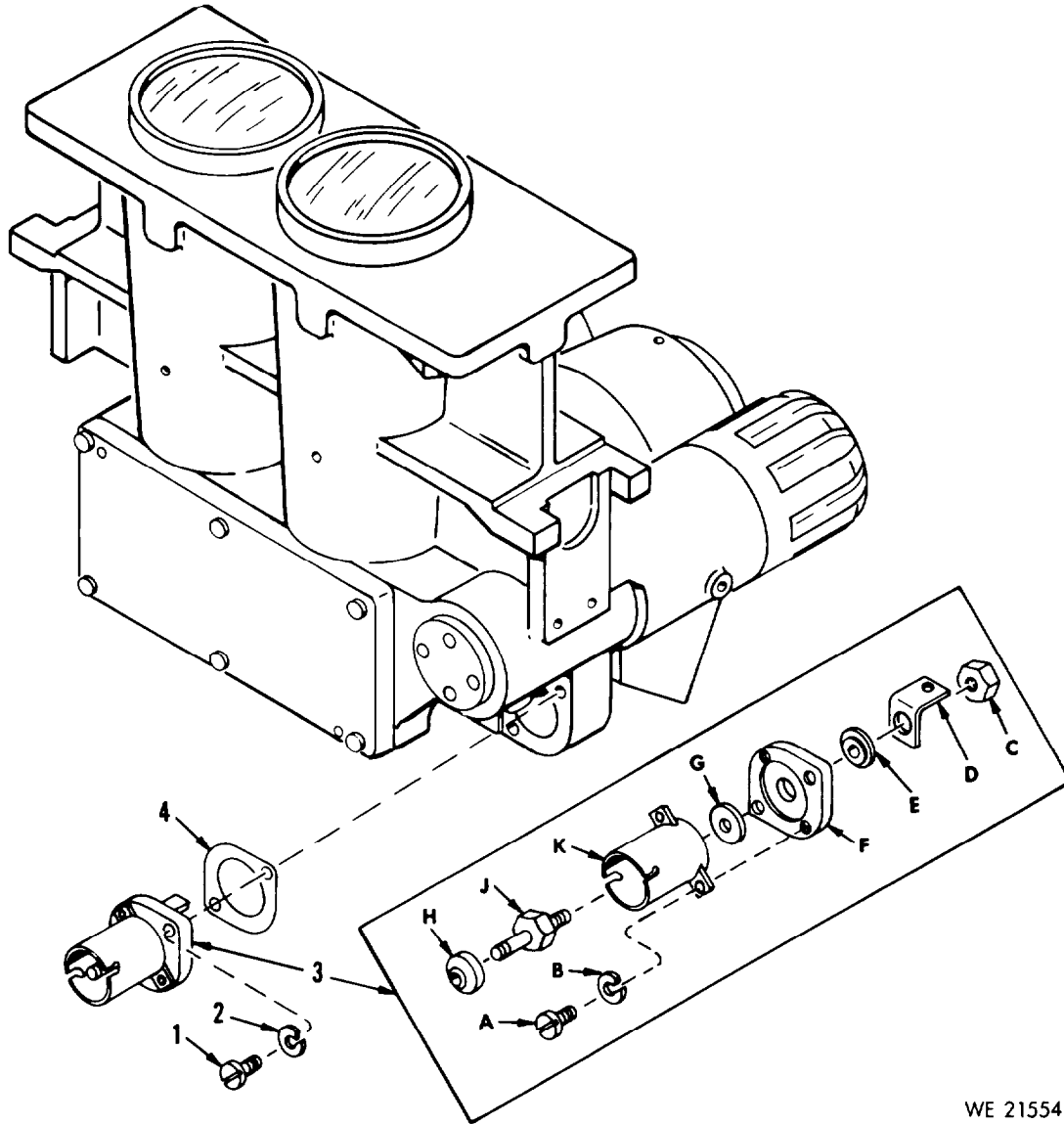

WE 21554

- | | |
|--|--|
| <p>1 — Screw, machine: pan hd, cross recess, no. 8-32
UNC-2A, 5/8 lg 5305-054-6671</p> <p>2 — Washer, lock: no. 8 (2) 5310-042-9067</p> <p>3 — Plug, contact and related parts</p> <p>A — Screw, machine, pan hd, cross recess, no.
4-40NC, 3/16 lg (2) MS35216-11</p> <p>B — Washer, lock, no. 4 (2) MS35337-78</p> <p>C — Nut, plain, hexagon: no. 6-32UNC-2B,
5310-271-4644</p> | <p>D — Terminal lug MS35431-4</p> <p>E — Insulator, disk: 5970-548-9392</p> <p>F — Plate 10513562</p> <p>G — Insulator, disk: 5970-548-9392</p> <p>H — Bushing, rubber: 5340-664-0095</p> <p>J — Plug, contact: 1290-764-9178</p> <p>K — Shell 8229046</p> <p>4 — Gasket 5330-912-4852</p> |
|--|--|

Figure 5-4. Contact plug 1290-764-9178 and related parts—partial exploded view

(11) Make sure the contact ends of the power supply provide a good electrical contact.
c. Installation.

(1) Assemble items in reverse sequence (1, fig. 5-7).

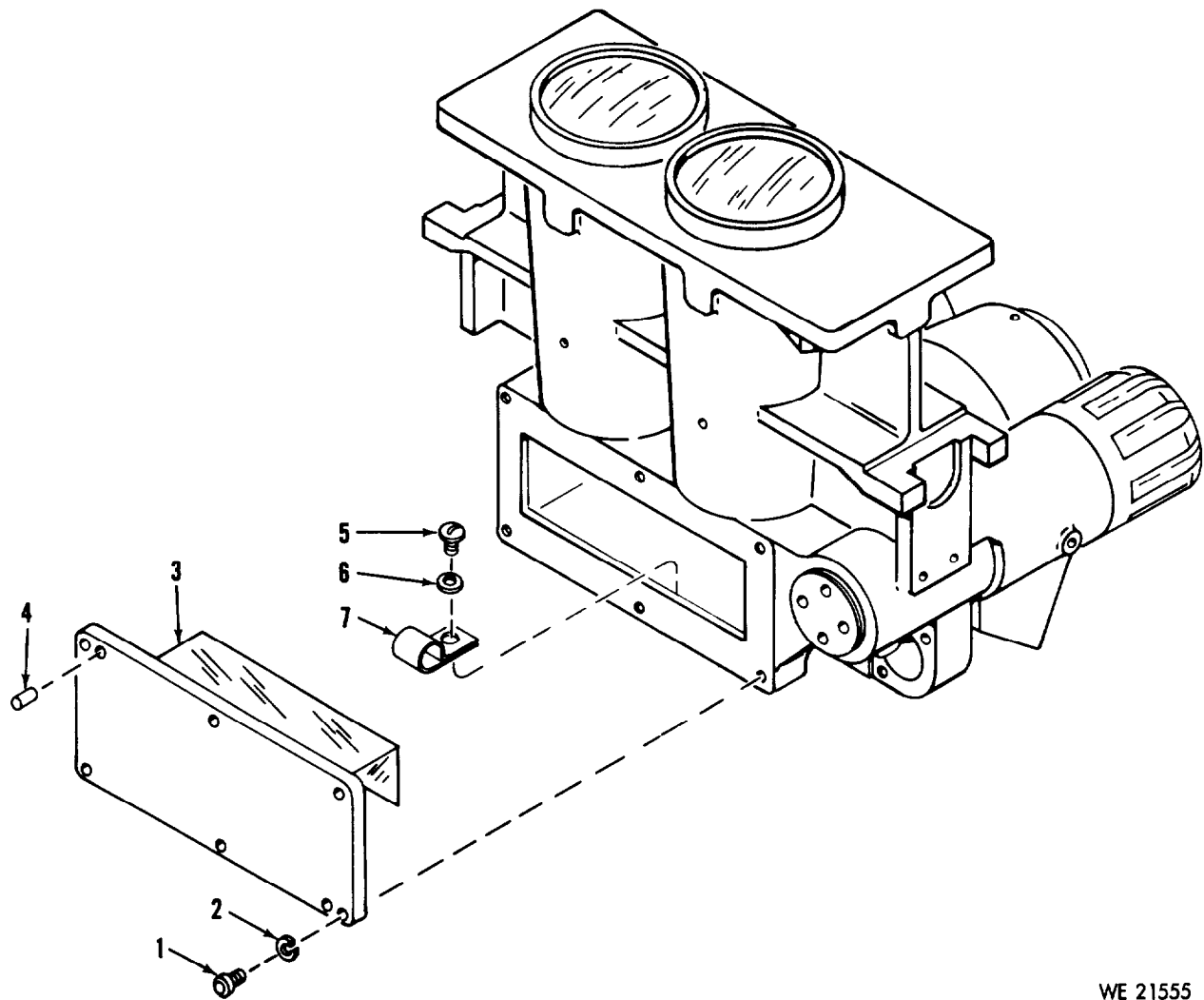

WE 21555

- 1—Screw, machine: pan hd, cross recess no. 6-32
UNC-2A, 1/2 lg (6) 5305-054-6654
- 2—Washer, lock: no. 6 (6) 5310-043-1754
- 3—Prism, optical instrument, mounted: 1240-
907-6512

- 4—Pin, straight headless, 1/8 by 3/8 lg (2)
16555-625
- 5—Screw, machine, pan hd, cross recess no. 8-32
NC, 1/2 lg MS35216-38
- 6—Washer, flat: no. 8 MS15795-807
- 7—Strap, retaining 10905840

Figure 5-5. Optical instrument prism 240-907-6512 and related parts-partial exploded view.

(2) Assemble in sequence items 10 through 1, applying a small amount of sealing compound, MIL-S-11031, to the threads of setscrews, items 8 and 9.

5-12. Removal of Electron Tube
5960-082-3326

a. Removal. Remove items 1 through 3 (fig. 5-8).

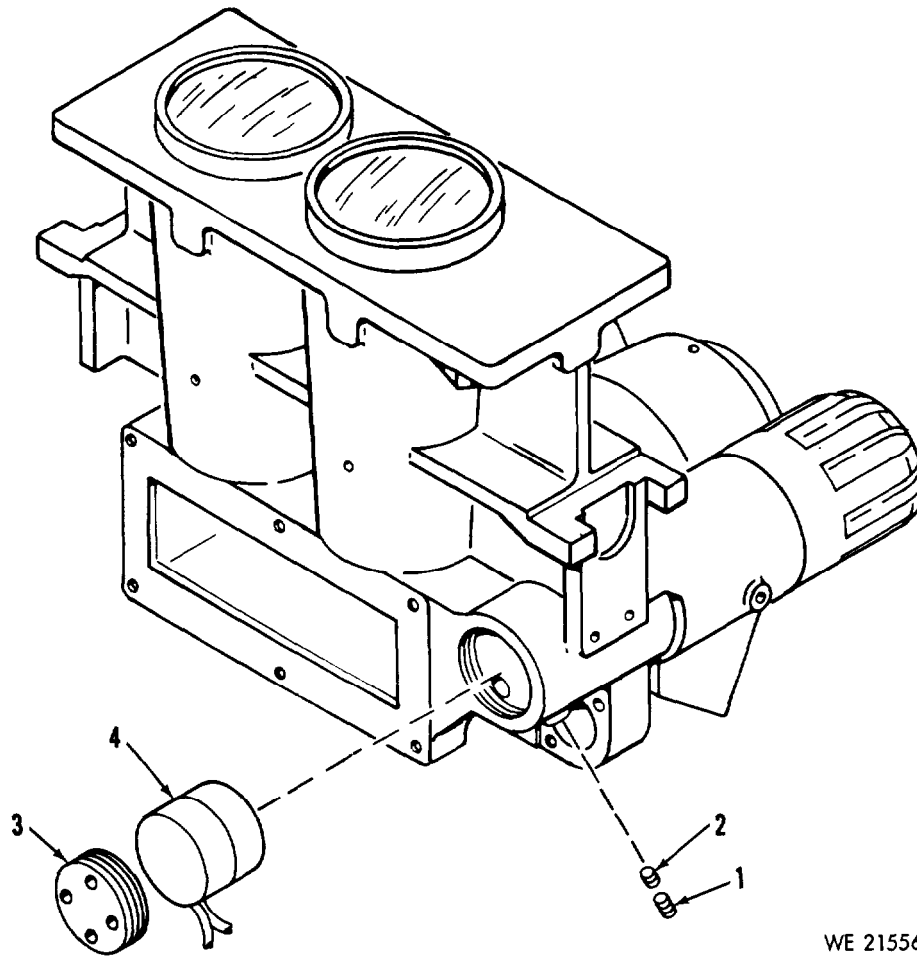

WE 21556

1-Setscrew: hdls, soc no. 6-32 NC-3A, 1/4 lg
5305-068-1655

%-Setscrew: hdls, soc no. 6-32 NC-3A, 1/8 lg
5305-531-0137

3-Plug 8589801
J-Connector, plug electrical : molded 6650-908-
1983

Figure 5-6. Connector 6650-908-1983 and related parts-partial exploded view.

- (1) Inspect the electron tube for cracks, dents, breaks, dirt and/or corrosion.
 - (2) Inspect the contact surfaces and determine that they will provide good electrical contact.
 - (3) Inspect the cell for cracks, dents, breaks, dirt and/or corrosion.
 - (4) Inspect all lens surfaces for scratches, dirt or cracks.
 - (5) Inspect all threaded surfaces for damage or conditions which could in any way impair proper seating of parts.
 - (6) Inspect retainer rings for tears, wear or corrosion.
- c. *Cleaning.* If corrosion is present use a fine crocus cloth to clean the affected areas and areas where electrical contact is made.
- d. *Installation.* Assemble items 3 through 1 (fig. 5-8).

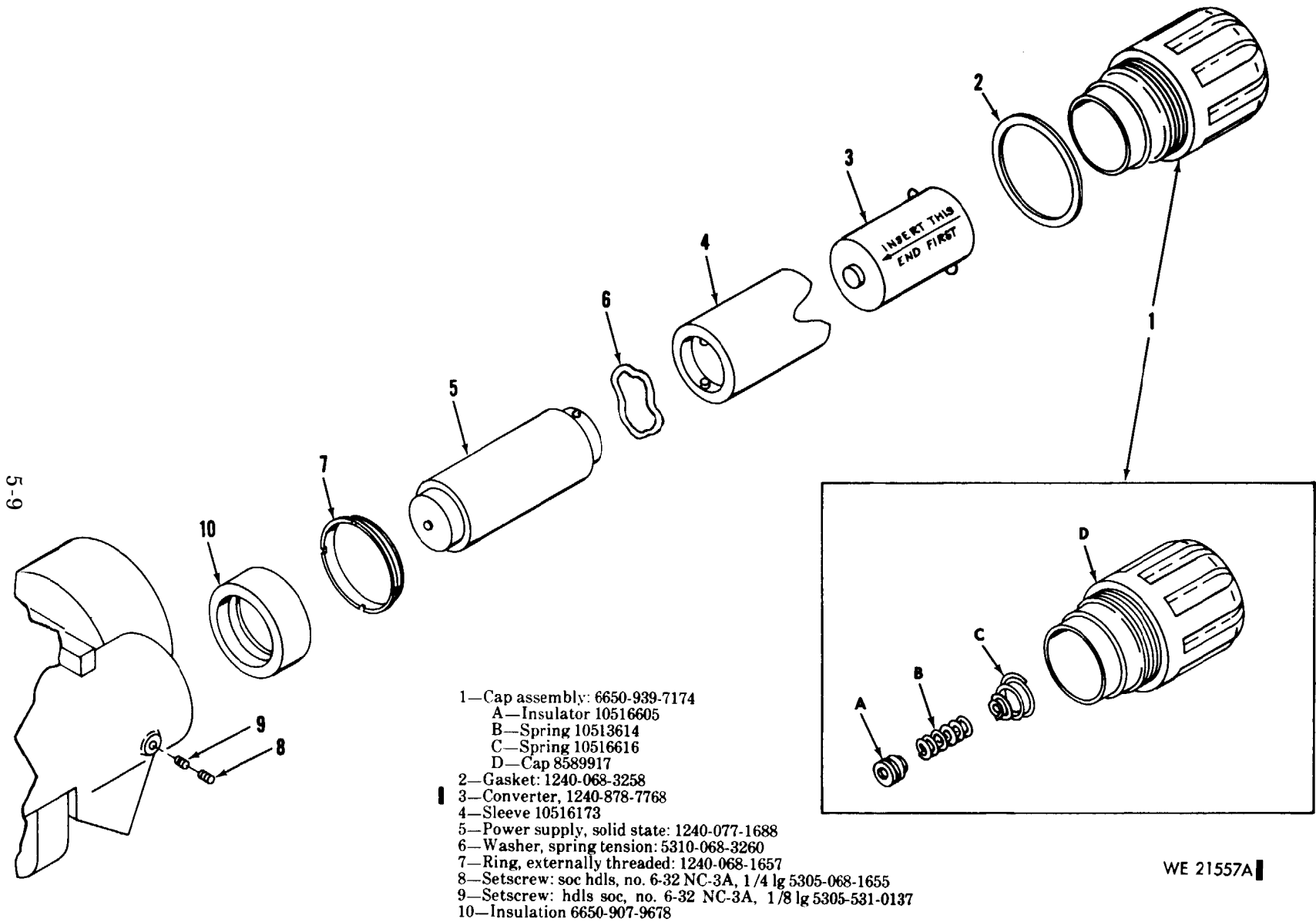

- 1—Cap assembly: 6650-939-7174
 - A—Insulator 10516605
 - B—Spring 10513614
 - C—Spring 10516616
 - D—Cap 8589917
- 2—Gasket: 1240-068-3258
- 3—Converter, 1240-878-7768
- 4—Sleeve 10516173
- 5—Power supply, solid state: 1240-077-1688
- 6—Washer, spring tension: 5310-068-3260
- 7—Ring, externally threaded: 1240-068-1657
- 8—Setscrew: soc hdls, no. 6-32 NC-3A, 1/4 lg 5305-068-1655
- 9—Setscrew: hdls soc, no. 6-32 NC-3A, 1/8 lg 5305-531-0137
- 10—Insulation 6650-907-9678

WE 21557A

Figure 5-7. Solid state power supply 1240-077-1688 and related parts—exploded view.

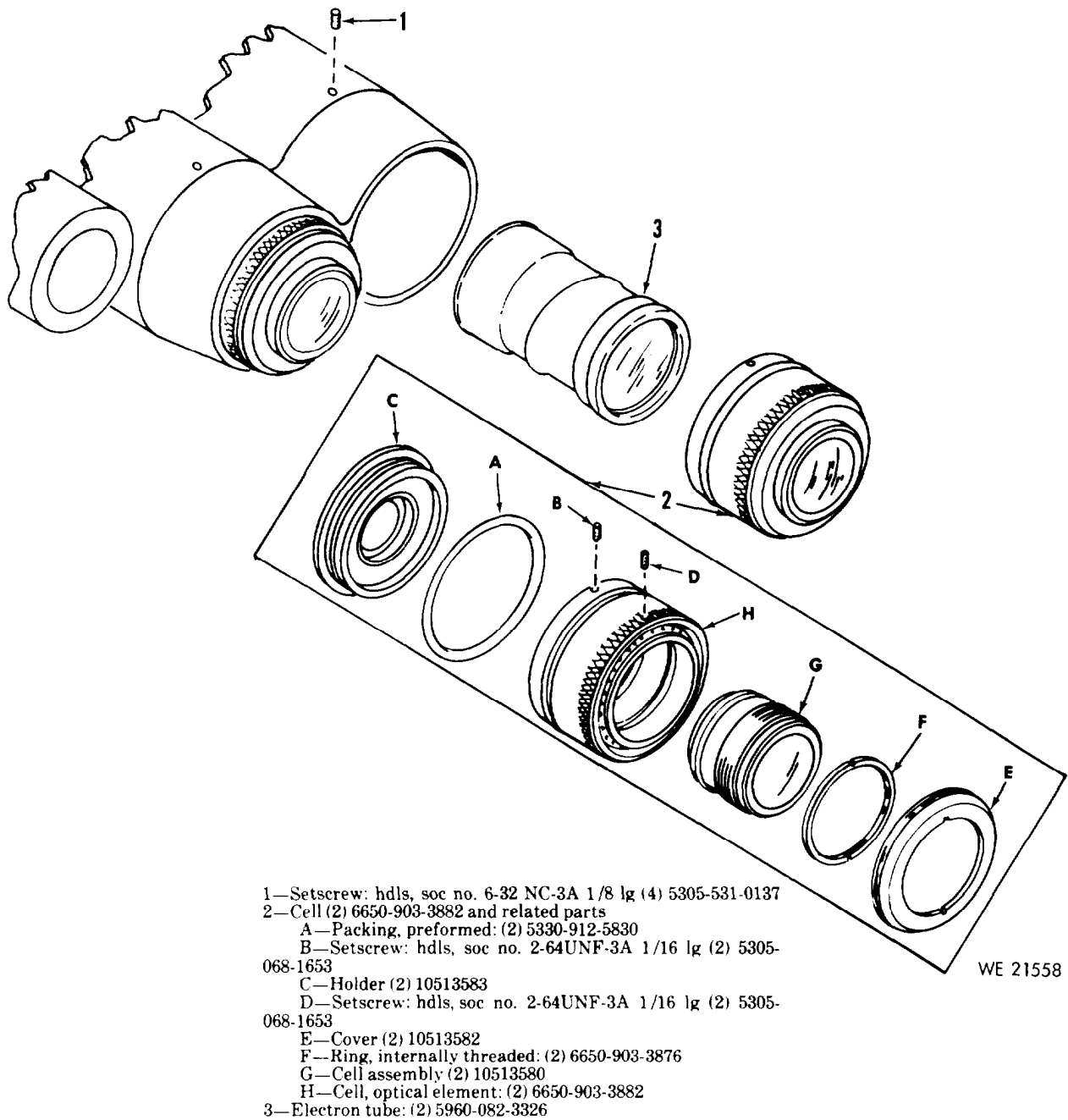

- 1—Setscrew: hdls, soc no. 6-32 NC-3A 1/8 lg (4) 5305-531-0137
- 2—Cell (2) 6650-903-3882 and related parts
 - A—Packing, preformed: (2) 5330-912-5830
 - B—Setscrew: hdls, soc no. 2-64UNF-3A 1/16 lg (2) 5305-068-1653
 - C—Holder (2) 10513583
 - D—Setscrew: hdls, soc no. 2-64UNF-3A 1/16 lg (2) 5305-068-1653
 - E—Cover (2) 10513582
 - F—Ring, internally threaded: (2) 6650-903-3876
 - G—Cell assembly: (2) 10513580
 - H—Cell, optical element: (2) 6650-903-3882
- 3—Electron tube: (2) 5960-082-3326

WE 21558

Figure 5-8. Electron tube 5960-082-3326 and related parts partial exploded view.

5-13. Test and Adjustment

Purging and Charging Body Assembly 10513599.
Remove cap (4A, fig. 5-2), plug

(5) and gasket (6). Purge and charge body assembly 10513599 as follows (fig. 5-15).

Note. The key numbers shown in parentheses refer to figure 5-15 unless otherwise indicated.

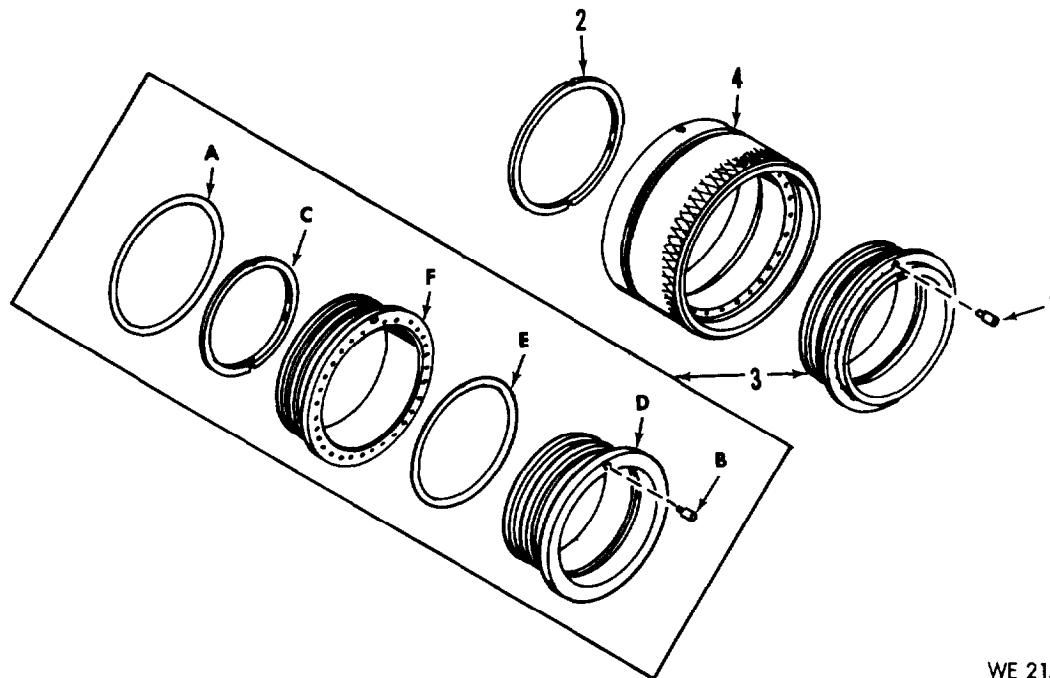

WE 21559

- | | |
|---|--|
| 1—Setscrew: hdls, soc no. 2-56UNC-3A, 0.160
lg (2) 5305-912-2693 | C—Ring, internally threaded: (2) 6650-904-5681 |
| 2—Ring, internally threaded: (2) 6650-904-5682 | D—Eccentric (2) 10513591 |
| 3—Eccentric (2) 10513587 | E—Packing, preformed: (2) 5330-912-6256 |
| A—Packing, preformed: (2) 5330-912-5814 | F—Eccentric (2) 10513587 |
| B—Setscrew: hdls soc no. 2-56UNC-3A, 0.160
lg (2) 5305-912-2693 | 4—Cell, optical element: (2) 6650-903-3882 |

Figure 5-9. Cell 6650-903-3882 and related parts-exploded view.

- (1) Remove threaded protective cover from the valve outlet of the dry nitrogen tank (1) and momentarily open the valve to clear foreign matter from the valve seat.
- (2) Check the nitrogen filling adapter (2) for cleanliness and proper sealing of gasket. Attach adapter to cylinder valve, and then attach helium pressure regulator (3) to adapter.
- (3) Remove cap from the low-pressure port of the regulator; connect rubber hose assembly (4) to low pressure port of the regulator.
- (4) Rotate valve of pressure regulator fully counterclockwise to close regulator.
- (5) Open valve of nitrogen tank slowly until cylinder pressure is registered on high pressure gage; indication shall not be less than 100 psi.
- (6) Slowly rotate valve of pressure regulator clockwise until approximately 5 psi is registered on the low pressure gage. Check free end of hose assembly for free flow of nitrogen for approximately 1/2 minute; then, rotate valve of pressure regulator fully counterclockwise to stop the flow of nitrogen.
- (7) Connect free end of hose assembly to valve of body assembly.
- (8) Slowly rotate valve of the pressure regulator clockwise until low pressure gage indicates 5 psi. Allow the

Note. If pressure indicated is less than 100 psi, obtain and use a replacement tank.

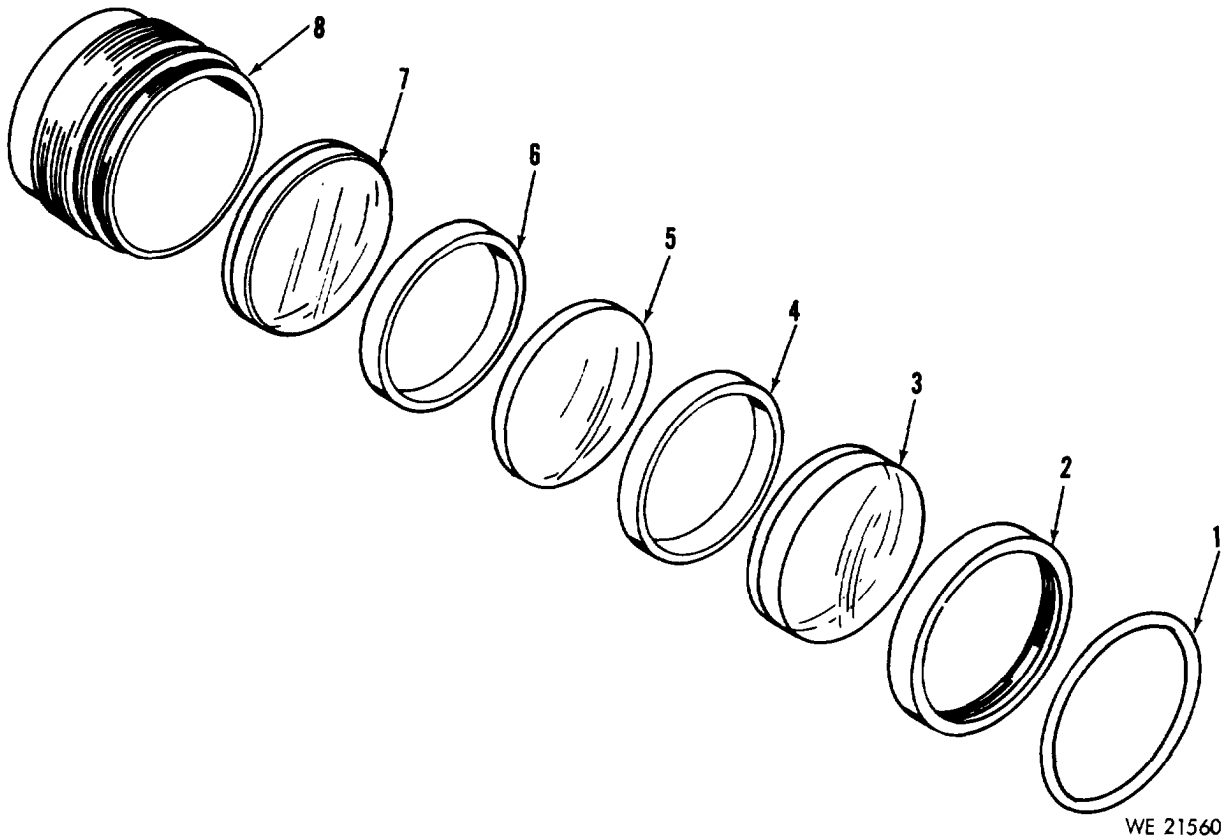

1—Packing, preformed: (2) 5330-912-4842
 2—Ring, internally threaded: 6650-902-8487
 3—Lens, optical instrument: 6650-903-7225
 4—Spacer 10513578

5—Lens, optical instrument: 6650-902-9739
 6—Spacer 10513578
 7—Lens, optical instrument: 6650-902-9740
 8—Cell 10513579

Figure 5-10. Cell assembly 10513579 — exploded view.

nitrogen to flush the assembly for 5 minutes,

- (9) Install gasket (6, fig. 5-2) and machine thread plug (5, fig. 5-2) securely in housing assembly.
- (10) Apply a water and soap solution around optical elements, the valve, and plug and check for leaks.
- (11) Reduce the pressure to 1 psi by slowly rotating valve of the pressure regulator counterclockwise. Charge for two minutes.

b. Final Test.

- (1) Rotate valve of pressure regulator fully counterclockwise to stop the flow of nitrogen. Close the valve of the nitrogen cylinder and remove the hose from the valve of the charged assembly.
- (2) Connect hose assembly (5) to dial indicating test gage assembly (6).
- (3) Connect the free end of the hose with gage assembly, to the valve of the charged assembly. The indicated pressure should be 0.5 to 1.0 psi.

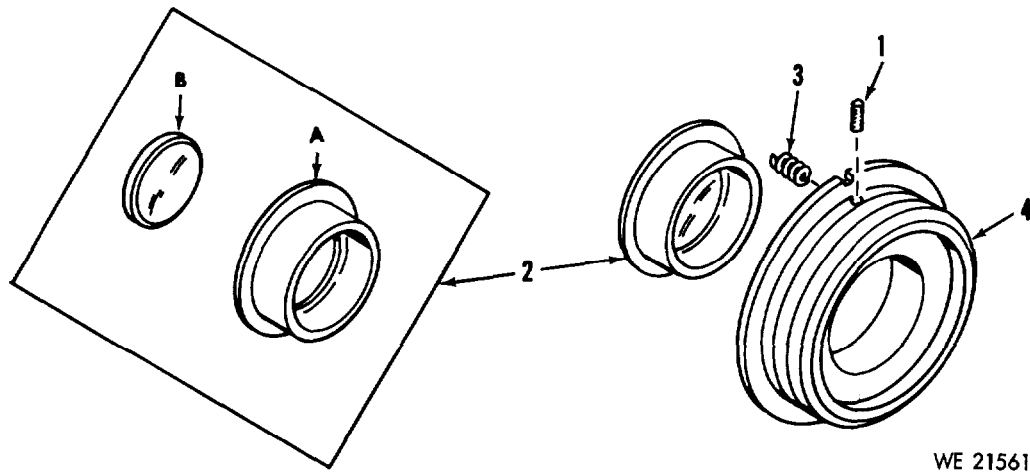

- 1—Setscrew: hdls, soc no. 6-32UNC-3A 0.500 lg
(2) 5305-054-9250
- 2—Cell assembly, optical instrument: 1240-907-6513
- A—Cell 10513563

- B—Lens (2) 10514278
- 3—Spring, helical compression: (6) 5340-912-2671
- 4—Holder (2) 10513583

Figure 5-11. Holder 10513583—exploded view.

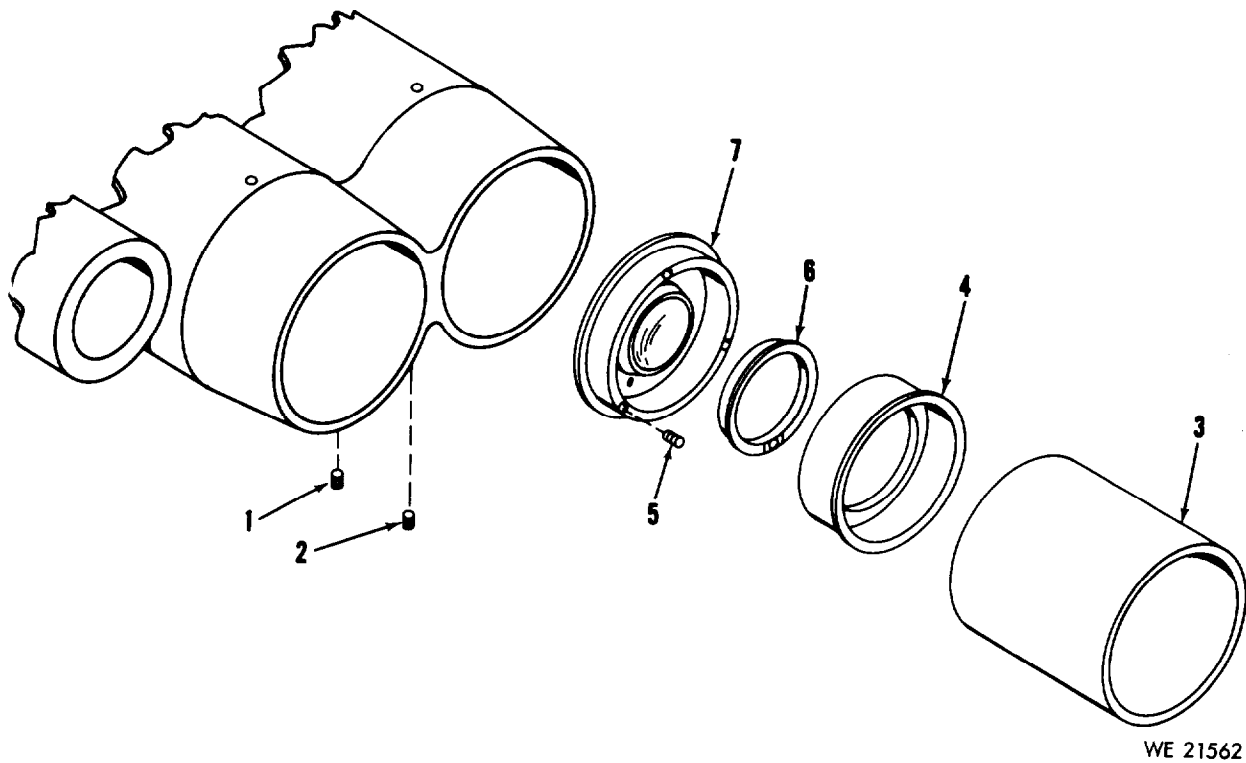

1—Setscrews: soc hdls, no. 10-24 NC-3A, 3/16
lg (2) 5305-753-4451

2—Setscrew, no. 10-24 UNC-3A, 1/4 lg (2)
MS51045-40

3—Shield (2) 10513576

4—Contact, electrical: (2) 6650-907-9677

5—Spring, helical, compression: (6) 5340-912-
2672

6—Ring (2) 10513568

7—Adapter: (2) 1240-907-6510

Figure 5-12. Adapter 1240-907-6510 and related parts — exploded view.

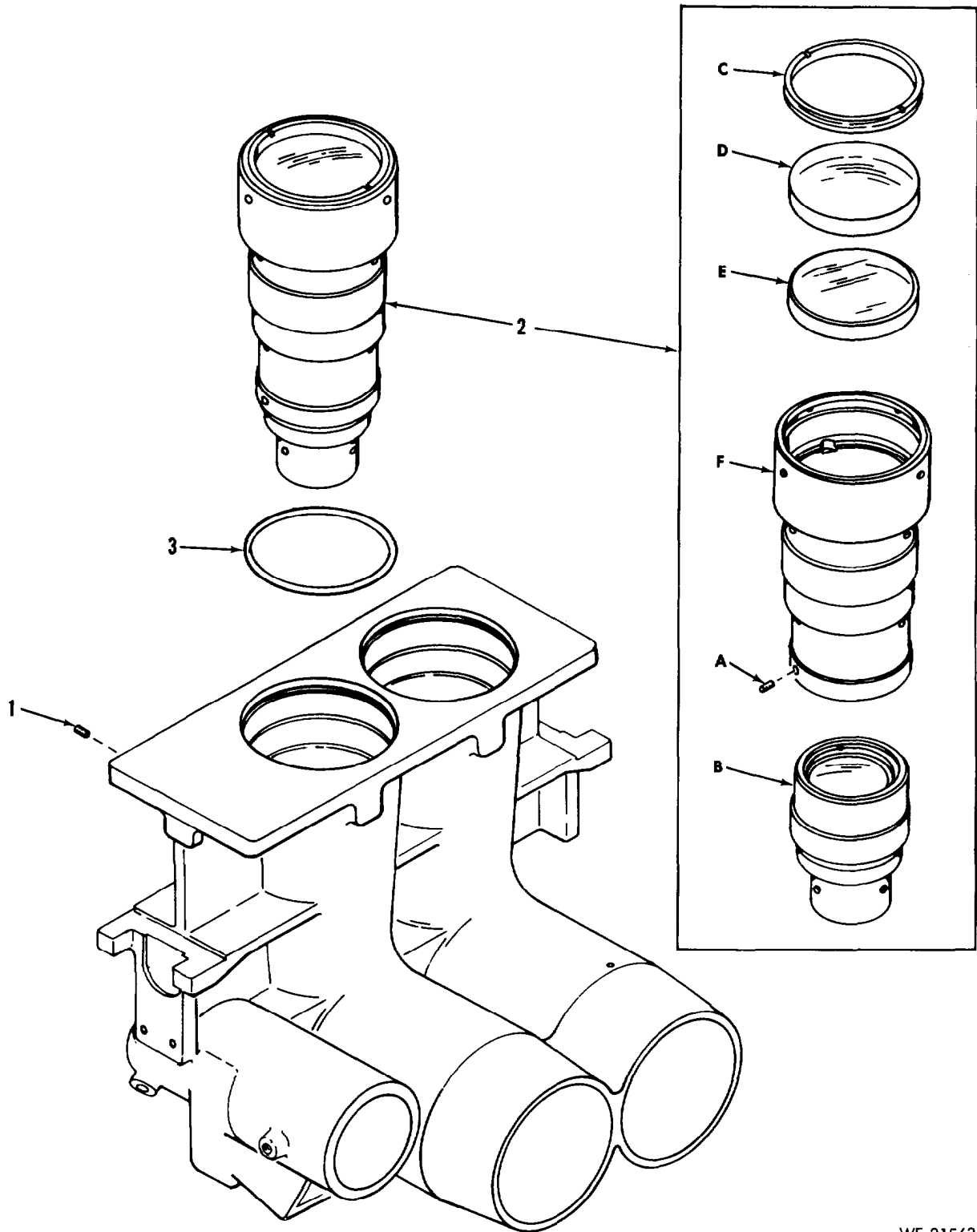

WE 21563

Figure 5-13. Housing 10513565 and related parts-partial exploded view.

1--Setscrew, soc hdls, no. 8-32 NC-3A, 3/16
 lg (2) 5305-551-0156
 2-Housing (2) 10513565 and related parts
 A-Setscrew: hdls, slot no. 2-64 NF-2A,
 0.094 lg (2) 5305-081-9735
 B-Cell (2) 10513564

C-Retainer, optical element: (2) 6650-902-7076
 D-Lens, optical instrument: (2) 6650-904-4570
 E-Lens, optical instrument: (2) 6650-902-9736
 F-Housing (2) 10513565
 3-Packing, preformed : (2) 5330-912-5829

Figure 5-13-Continued.

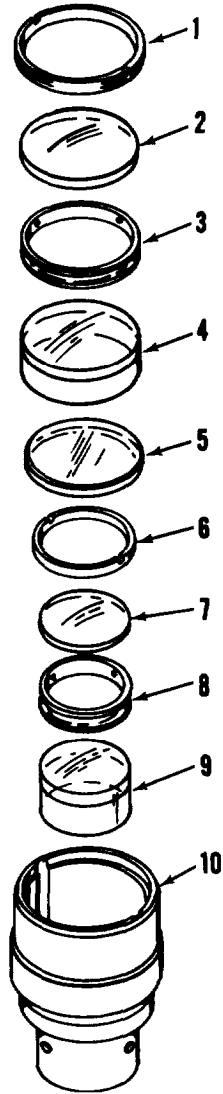

WE 21564

1-Retainer, optical element: (2) 6650-902-7074
 P-Lens, optical instrument: (2) 6650-902-9737
 3-Spacer (2) 10513657
 4-Lens (2) 7688725
 5-Filter, light: (2) 1240-768-8724

6-Retainer, optical element: (2) 6650-902-7076
 7-Lens optical instrument: (2) 1240-768-8722
 8-Spacer (2) 10513566
 9-Lens, optical instrument: (2) 1240-768-8718
 10-Cell (2) 10513564

Figure 5-14. Cell 10513564 and related parts-partial exploded view.

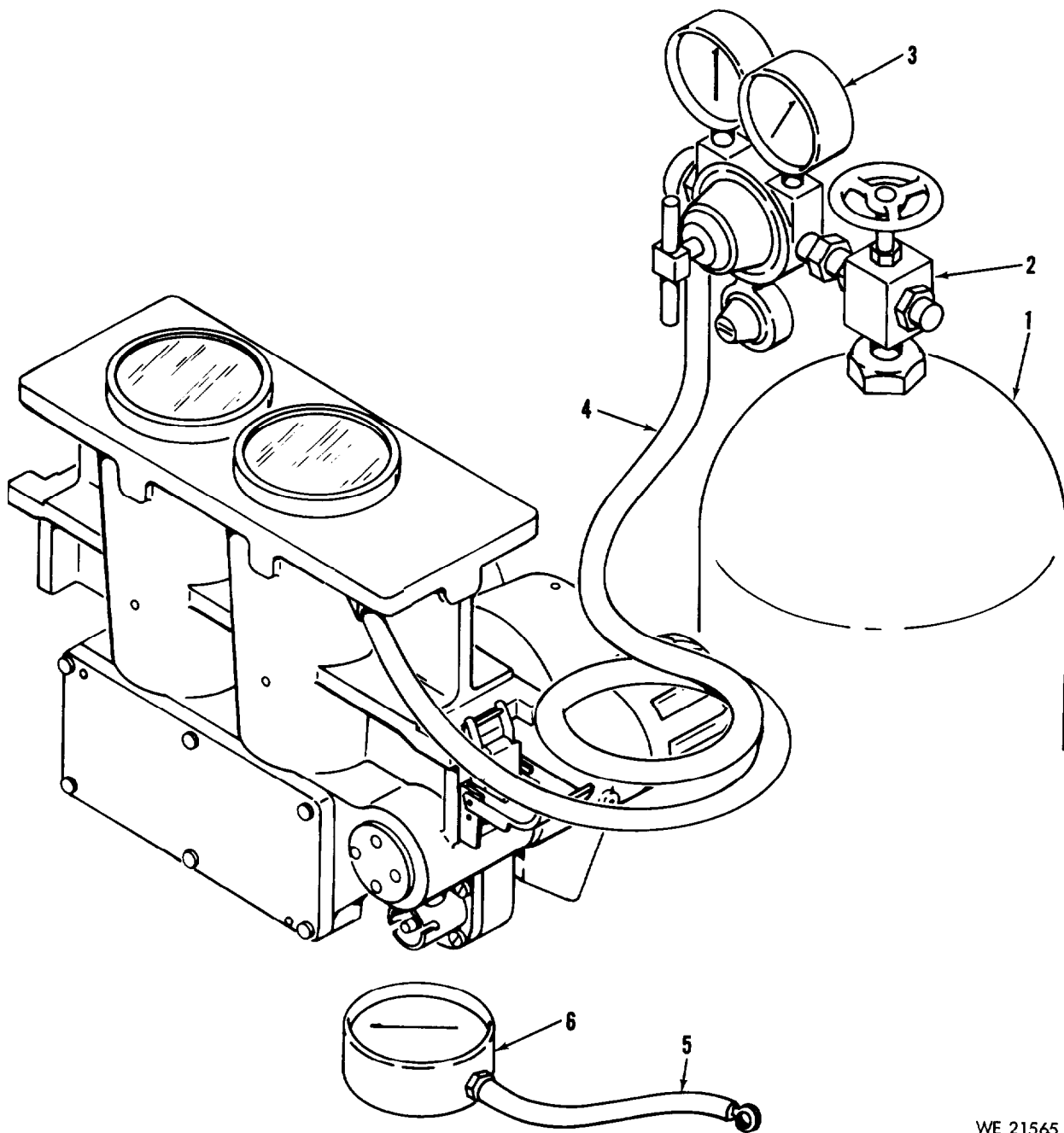

WE 21565

- 1-Tank, nitrogen : 6830-264-9086
- 2-Adapter, nitrogen filling: 4931-508-5453
- 3-Regulator, helium pressure: 1240-558-0922

- 4-Hose assembly, rubber: 4931-561-0713
- 5-Hose assembly: 4931-508-5546
- 6-Test gage assembly: 4931-546-9773

Figure 5-15. Typical setup for purging and charging periscope XM48.

CHAPTER 6

EQUIPMENT ISSUED WITH PERISCOPE XM48

Section I. DESCRIPTION

6-1. General

a. (Equipment used with periscope XM48 includes mount assembly 6650-906-7944, seal assembly 10513439, washer, pump, and reservoir assembly 8589793, wiper assembly 10513436, and headrest assembly 6650-907-9679. This chapter provides repair instructions for headrest assembly. Repair instructions for the other equipment supplied with periscope XM48 are provided in TM 9-6650-221-35 periscope, tank, XM47.

b. Headrest assembly 6650-907-9679 is secured to mount assembly 6650-906-7944 with two machine screws and provides a padded rest for the operator's forehead when viewing the binocular tubes of periscope XM48. The headrest is adjustable to fit the operator's forehead position through a swivel mounting arrangement.

6-2. Description of Headrest Assembly 6650-907-9679

a. Headrest assembly 6650-907-9679 is a three-piece assembly that consists of headrest

assembly 6650-907-9680, housing 8589902, and slide 10511392 (fig. 6-1). Slide 10511392 is secured to the front of mount assembly 6650-906-7944 and is used for mounting the combination housing and headrest assembly 6650-907-9680.

b. Housing 8589902 (fig. 6-1) contains two mounting grips, one for securing the housing to the slide and one for securing headrest assembly 6650-907-9680 to the housing. The housing mounting grip controls a spring-loaded plunger that engages a hole in the slide when the housing is positioned on the slide. The headrest mounting grip controls a spring-loaded plunger that engages a hole in the support of headrest 6650-907-9680 when the headrest assembly is mounted to the housing.

c. Headrest assembly 6650-907-9680 (fig. 6-1) consists of headrest 10513499 which is attached to a mounting support through a swivel arrangement. Swivel 10513498 is a ball swivel that is controlled for tightness by the position of knob 10511395 to permit positioning of the headrest.

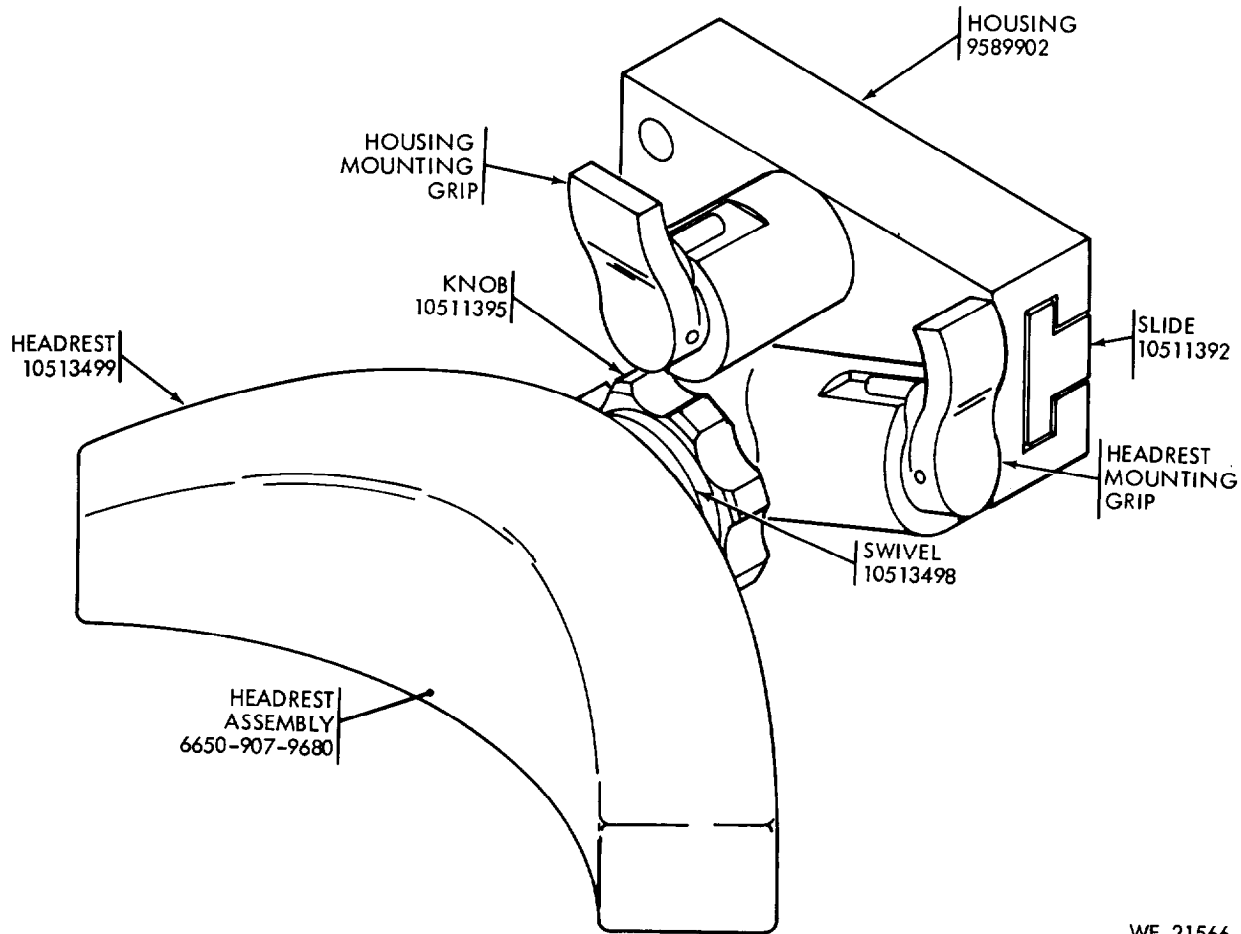

WE 21566

Figure 6-1. Headrest assembly 6650-907-9679.

Section II. REPAIR OF HEADREST ASSEMBLY 6650-907-9679

6-3. Inspection

- a. Note the general appearance of the headrest assembly to determine the type of treatment it has received.
- b. Inspect the padding on the headrest for tears, cuts, or other signs of damage that would render it unserviceable.
- c. Ensure that the padding is properly and securely cemented to the headrest plate.
- d. Check for smooth and positive positioning of the headrest.
- e. Ensure that the knob is free to turn and that it will tighten and loosen the headrest in the swivel mount.
- f. Check for the smooth and positive operation of the headrest mounting grip.

g. Ensure that the spring-loaded plunger properly engages the headrest assembly support when the headrest assembly is installed.

h. Check for the smooth and position operation of housing mounting orip.

i. Ensure that the spring-loaded plunger properly engages the slide when the housing is mounted.

j. Ensure that the stop pin is installed on the slide and that the housing strikes the stop when it is installed.

k. Ensure that the complete assembly is free from dirt and grit.

1. Refer to Basic Issue Items List in TM 9-2350-230-12 and check for completeness of repair parts, tools and equipment.

6-4. Troubleshooting

Troubleshooting procedures applicable to direct support, general support, and depot

maintenance personnel are covered in table 6-1. Refer to TM 9-2350-230-12 for troubleshooting procedures applicable to operator's and organizational maintenance personnel.

Table 6-1. Troubleshooting, Headrest Assembly 6650-907-9679

Malfunction	Probable cause	Corrective action	Lowest maintenance category
1. Headrest will not retain position.	a. Headrest support 6650-908-1984 (15, fig. 6-2) is worn.	a. Replace headrest support 6650-908-1984 (para 6-5).	DS
	b. Swivel 10513493 (1B, fig. 6-2) is worn.	h. Replace swivel.	Depot
2. Headrest assembly loose in housing.	a. Setscrew 5305-905-3050 (14, fig. 6-2) is worn or loose.	a. Tighten or replace setscrew applying sealing compound, MIL-S-11031 to the threads before tightening	DS
	h. Helical compression spring 5340-912-2670 (12, fig. 6-2) is worn or broken.	h. Replace helical compression spring (para 6-6).	DS
3. Headrest mounting grip loose.	a. Externally threaded ring 10513488 (11, fig. 6-2) is worn or loose.	a. Tighten or replace externally threaded ring (para 6-6).	DS
	b. Helical compression spring 5340-912-2670 (12, fig. 6-2) is worn or broken.	b. Replace helical compression spring (para 6-6).	DS
4. Housing loose on slide.	Helical compression spring 5340-912-2670 (6, fig. 6-12) is worn or broken.	Replace helical compression spring (para 6-7).	DS
5. Housing mounting grip loose.	a. Externally threaded ring 10513488 (5, fig. 6-2) is worn or loose.	a. Tighten or replace externally threaded ring (para 6-7).	DS
	h. Helical compression spring 5340-912-2670 (12, fig. 6-2) is worn or broken.	b. Replace helical compression spring (para 6-7).	DS

6-5. Replacement of Headrest Support 6650-908-1984

a. Removal. Remove items 1, 14, and 15 (fig. 6-2) lifting item 10 to remove item 15.

b. Inspection Inspect the general condition of the headrest support, paying particular attention to the condition of the ball joint seat. Insure that there is no excessive wear in the seat and that the seat is not gouged or nicked. Inspect the mounting holes that engage the plunger for roundness. Inspect the threads that engage the knob for wear, burrs, or other signs of unserviceability.

c. Installation.

- (1) Assemble item 15 to item 16 (fig. 6-2) and orient the mounting hole to engage the plunger, item 13.
- (2) Install item 14 (fig. 6-2) apply a small amount of sealing compound ML-S-11031 to the threads.
- (3) Install item 1 (fig. 6-2) and tighten knob (IA) to obtain desired friction setting.

6-6. Repair of Housing Retaining Plunger

a. Removal. Disassemble items 3 through 7 (fig. 6-2).

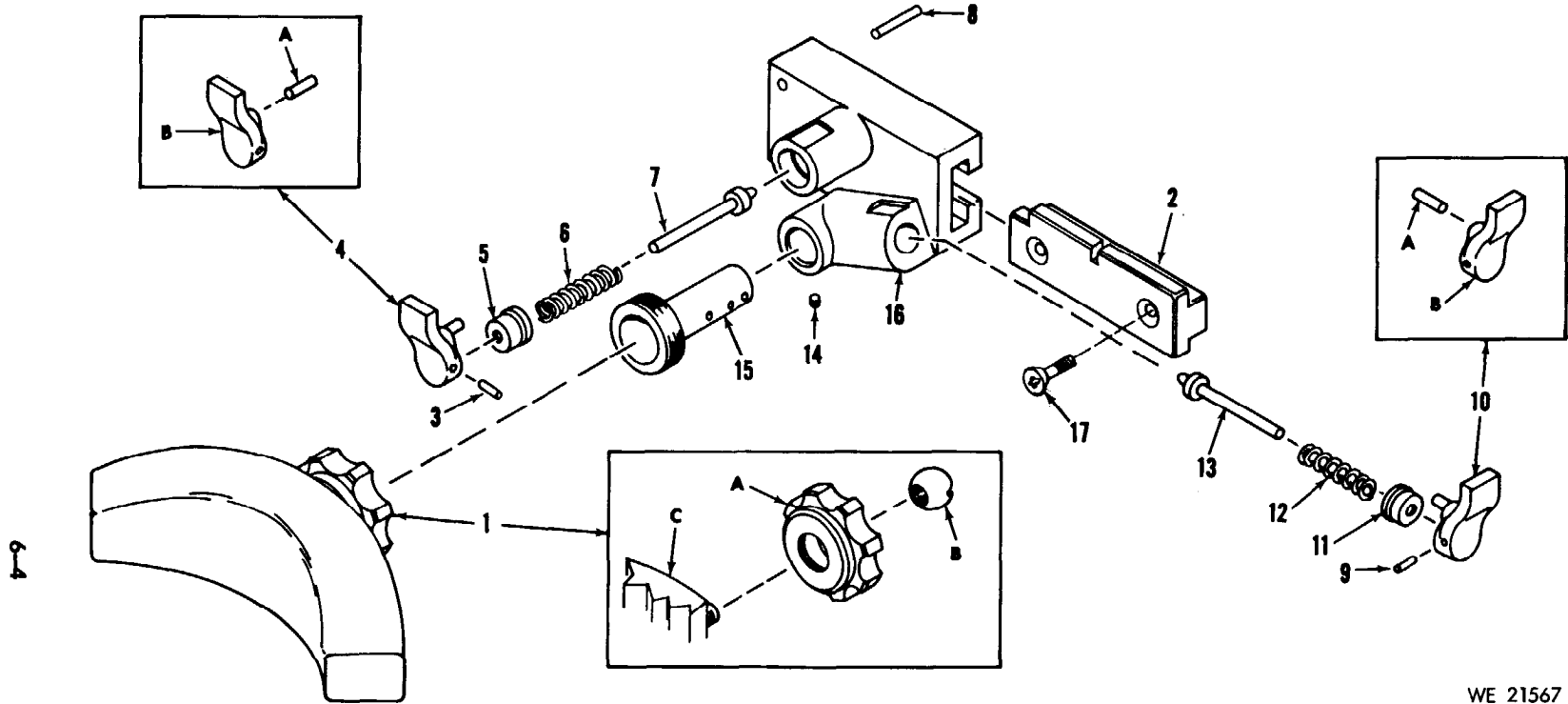

WE 21567

- 1—Headrest assembly: 6650-907-9680
 - A—Knob 10511395
 - B—Swivel 10513498
 - C—Headrest 10513499
- 2—Slide 10511392
- 3—Pin, straight headless, 1/16 by 1/2 lg MS16555-606
- 4—Grip: 6650-944-5150
 - A—Pin, straight headless, 1/8 by 3/4 lg MS16555-629

- B—Grip 8589817
- 5—Ring, externally threaded 10513488
- 6—Spring, helical compression 5340-912-2670
- 7—Plunger 10511397
- 8—Pin, straight headless, 1/8 by 3/4 lg MS16555-629
- 9—Pin, straight headless, 1/16 by 1/2 lg MS16555-606
- 10—Grip: 6650-944-5150

- A—Pin, straight headless, 1/8 by 3/4 lg MS16555-629
- B—Grip 8589817
- 11—Ring, externally threaded 10513488
- 12—Spring, helical compression: 5340-912-2670
- 13—Plunger 10511397
- 14—Setscrew: hdls, dog point, no. 6-40 UNF-3A by 3/4 lg 5305-905-3050
- 15—Support, headrest: 6650-908-1984
- 16—Housing 8589902

Figure 6-2. Headrest assembly 6650-907-9679-exploded view.

b. Inspection. Inspect the disassembled parts for excessive wear or damage. Check the helical compression spring for cracks, breaks, or loss of resiliency.

c. Installation. Assemble, in sequence, items 7,6,5,4, and 3 (fig.6-2), applying a small amount of sealing compound MIL-S-11031 to the threads of the externally threaded retaining ring (5).

6-7. Repair of Headrest Retaining Plunger

a. Removal.

- (1) Remove item 1 (fig. 6-2).
- (2) Disassemble items 9 through 13 (fig. 6-2).

b. Inspection. Inspect the disassembled parts for excessive wear or damage. Check the helical compression spring for cracks, breaks, or loss of resiliency.

c. Installation.

- (1) Assemble, in legend sequence, items 13,12,11,10, and 9 (fig. 6-2), applying a small amount of sealing compound MIL-S-11031, to the threads of the externally threaded retaining ring (5).
- (2) Install item 1 (fig. 6-2) and tighten knob (1A) to obtain desired friction setting.

CHAPTER 7
PROCESSING AND PACKAGING

7-1. General

After the components of periscope XM48 have been repaired, inspected, declared serviceable and reassembled, the processing and packaging procedures of this chapter should be followed to assure that serviceability will be maintained.

7-2. Optical Components

Cover all prisms or optical elements with at least four thicknesses of neutral lens tissue and secure in place with water-resistant, pres-

sure-sensitive adhesive tape. Cover the lens tissue with cellulosic cushioning material and secure in place with pressure-sensitive tape.

7-3. Final Packaging of Periscope XM48

Final packaging of periscope XM48 shall be in accordance with MIL-P-14232/P10516 700.

**7-4. Final Packaging of Headrest
Assembly 6650-907-9679**

Final packaging of headrest assembly shall be in accordance with MIL-P-14232/10513437.

APPENDIX I

REFERENCES

A-1. Supply Manuals

The following Department of the Army Supply Manuals pertain to repair and overhaul of this materiel:

Brushes, Paints, Sealers and Adhesives -----	SM 5-1-C5-1
Fire Control Maintenance and Repair Shop Specialized Equipment: Tool Set, Depot Maintenance, Supplementary Tools, Fixtures and Equipment (4931-798-7583).	SM 9-4-4931-540
Fire Control Maintenance and Repair Shop Specialized Equipment Tool Set, Field and Depot Maintenance, General Purpose, Special Tools (4931-574-6433).	SM 9-4-4931-551
Fire Control Maintenance and Repair Shop Specialized Equipment Tool Set, Special Depot Maintenance, Optical Cleaning, Coating, Cementing and Decementing (4931-535-7827).	SM 9-4-4931-548
Fire Control Maintenance and Repair Shop Specialized Equipment Wrench Set, Spanner, Field and Depot Maintenance: Tubr, Dble-End Concave Inserted Blade; Set of 76 Wrenches (4931-580-0012).	SM 9-4-4931-552
Fuels, Lubricants, Oils, and Waxes -----	SM10-1-C4-1
Hardware and Abrasives -----	SM9-1-C5300
Shop Set Field Maintenance: Instrument and Fire Control Basic (5180-754-0740).	SM 9-4-5180-B06
Tool Kit, Fire Control Repairman (5180-357-7735) -----	SM 9-4-5180-A61
Tool Kit, Instrument Repairman's (5180-357-7743) -----	SM 9-4-5180-A62

A-2. Other Publications

a. General.

Accident Reporting and Records -----	AR 385-40
Ordnance Direct Support Service -----	FM 9-3
Ordnance General and Depot Support Service -----	FM 9-4
The Army Equipment Record System and Procedures -----	TM 38-750

b. Maintenance.

Cleaning of Ordnance Materiel -----	TM 9-208-1
General Maintenance Procedures for Fire Control Materiel - - - - -	TM 9-254
Grease, Aircraft and Instrument (For Low and High Temperature) ---	MIL-G-23827
Lubricating Oil, Instrument, Aircraft, Low Volatility -----	MIG -L-6085
Lubrication of Ordnance Materiel -----	TM 9-273
DS, GS, and Depot Maintenance Manual Including Repair Parts and Special Tool Lists for Periscope, Tank: XM47 (6650-788-5464).	TM 9-6650-221-35

TM 9-6650-222-35

Operator's and Organizational Maintenance Manual Armored Recon- TM 9-2350-230-12
naissance-Airborne Assault Vehicle: FT, 152MM, XM551.
Organizational, DS, GS, and Depot Maintenance Repair Parts and Spe- TM 9-2350-230-
cial Tool Lists For Turret, Elevating and Traversing Systems, Cu- 25P/2
pola, Gun-Launcher and Fire Control For Armored Reconnaissance-
Airborne Assault Vehicle: FT, 152MM, XM551 (2350-873-5408).
Painting Instructions for Field Use----- TM 9-213
Sealing Compound, Adhesive Curing (Polysulfide Base) ----- MIL-S-11031
Sealing Compound, Non-curing (Polysulfide Base) ----- MIL-S-11030

c. Operations.

Auxiliary Sighting and Fire Control Equipment----- 9-575
Northern Operations ----- FM 31-71
Operation and Maintenance of Ordnance Materiel in Extreme Cold TM 9-207
Weather, 0° to -65°F.

d. Shipment and Storage.

Paper, Lens, Tissue, Antitarnish Wrapping ----- MIL-P-13988
Parts Equipment and Tools for Ordnance Materiel, Packaging of ----- MIL-P-1432/
P10516700
MIL-P-14232/
P10513437
Preservation,Methods of ----- MIL-P-116
Preservation, Packaging and Packing ----- AR 700-15

APPENDIX II

REPAIR PARTS AND SPECIAL TOOL LISTS
 FOR
 PERISCOPE, TANK: XM48
 (6650-762-9336)

SECTION I
 PREFACE

B-1. Requisition Notes

(a. When requisitioning an item, the requisitioning agency will order the listed item. However, the supplying agency will take necessary action to issue the exhaust stock item until stock is exhausted, whether it be an individual item, kit, set, or assembly.

b. Requisitions for replacement of items will be submitted through appropriate supply channels.

c. If the exact item requisitioned is not furnished or if other action is necessary, the exact nature of the action taken by the supplying agency will be indicated by standard symbols on prescribed forms.

(3) *Maintenance level (colm 1c)*. This column indicates the lowest category of maintenance authorized to install the listed item. The maintenance level codes used in this list are:

Code	Explanation
0	Organization maintenance (operator/crew).
F	Direct support maintenance.
D	Depot maintenance.

(4) *Recoverability (colm 1d)*. This column indicates whether unserviceable items should be returned for recovery or salvage. When no code is indicated, the item will be considered expendable and not recoverable. Recoverability code used in this list is:

Code	Explanation
R	Items which are economically repairable at direct support and general support activities and are normally furnished by supply on an exchange basis.

B-2. Explanation of Columns

a. *Source, Maintenance and Recoverability Code (Colm 1)*.

(1) *Material code no. (colm 1a)*. Not required.

(2) *Source (colm 1b)*. This column indicates the selection status and source for the listed item. Source codes used in this list are:

Code	Explanation
P	Requisition through appropriate supply channels (applies to high mortality parts).
P1	Requisition through appropriate supply channels (applies to low mortality parts).

b. *Federal Stock Number (Colm 2)*. This column indicates the Federal stock number which has been assigned by the Cataloging Division, Defense Logistics Service Center.

c. *Description (Colm 3)*. This column indicates the federal item name (shown in capital letters) and any additional description required for supply operations. The part number is also included for reference.

d. *Unit of Issue (Colm 4)*. This column indicates the quantity to be requisitioned.

e. *Quantity Incorporated in Unit (Colm 5)*. This column indicates the number of times the listed item is used in the functional unit.

f. *15-Day Maintenance Allowance Per 100 Equipments (Colm 6)*.

- (1) *Direct support and general support maintenance (colms 6a and 6b)*. These columns indicate repair part allowance factors for direct support and general support maintenance. These factors represent the estimated average quantities required to provide maintenance and, where applicable, supply support for 100 equipments for a 15-day period under combat conditions. The exact quantity authorized must be computed as instructed in (2) below. Additional repair parts which may be required for performing authorized maintenance but not authorized for stockage in the prescribed load, are indicated by an asterisk (*). These items are to be requisitioned as required. Where no quantity is shown, reference should be made in the description column.

Note. The 15-day level is not applicable special tools for direct support, general support, and depot maintenance.

- (2) *Computation of authorized quantities*. To compute the exact quantities authorized using the allowance factors, multiply the number of equipments supported by the allowance factor. Then divide by 100.

Example :

If the number of equipments supported is-----	30
and the allowance factor for 100 equipments is -----	x1.9

	270
	30

	57.0

The resulting product is ----- 57.0
 Divide this by 100 (this may be accomplished by moving the decimal point two places toward the left

thus: .570 or 0.570). When the resulting fractional value is .5 or larger, it will be rounded off to the next higher whole number.

Example :
 If 1.77 is obtained, a quantity of 2 is authorized. When the resulting fractional value is below, .5, it will be rounded to the next lower whole number.

Example :
 If 3.4 is obtained, a quantity of 3 is authorized.

g. *Depot Maintenance Guide Per 100 Equipments (Colm 7)*. This column indicates repair part allowance factors for depot maintenance. These factors represent recommended quantities required to over haul 100 components or end items of equipment. The exact quantity authorized must be computed as instructed in f(2) above. Where no quantity is shown, reference should be made in the description column.

Note. The 15-day level is not applicable to tools and equipment for direct support, general support, and depot maintenance personnel.

h. *Illustration (Colm 8)*.

- (1) This column indicates the figure number of the illustration that depicts the listed item. When more than one item appears on an illustration, the item number is also indicated.
- (2) Items that appear on the illustrations and in the legends of the illustrations but which are not listed in the tabular listing are nonsupply parts and are not authorized.

B-3. Abbreviations

Abbreviations	Explanations
al -----	aluminum
al aly -----	aluminum alloy
blk -----	black
brs -----	brass
cem -----	cement
cone pt -----	cone point
gres -----	corrosion-resistant steel
csk -----	countersink
cup pt -----	cup point
dbl -----	double
dia -----	diameter
dog pt -----	point
dr -----	drilled, drive

Abbreviations	Explanations
fin.....	finish
fp,	flat point
gl	glass
h	high
hdls	headless
hex.shld.....	hexagonshoulder
id.....	inside diameter
int thd.....	internal thread
lg	long,length
lkg.....	locking
It.....	.light
NC.....	American National Coarse Thread
NEF	American National Extra Fine Thread
no.....	number
* o/a.....	over-all
od	outside diameter
pan hd	pan head
pass. fin.....	passivated finish
plastic	plastic
r	ring
rd	round
rub.....	rubber
scr	screw
sect.....	section
sil ctd	silvercoated
slot	slotted

Abbreviations	Explanations
soc.....	socket
syn.....	synthetic
syn rub.....	synthetic rubber
thd.....	thread
thk.....	thick(ness)
UNC	American Unified Coarse Thread
UNEF	American Unified Extra Fine Thread.
UNF	American Unified Fine Thread
UNS.....	American Unified Special Thread
V	volt(s)
W	wide, width

B-4. Footnotes

¹ Used in lieu of power supply 10516120 to provide an alternate emergency power source for the periscope during the absence of vehicle power or the failure of the power supply.

² Dry batteries are used with, but not part of the equipment. They are to be requisitioned separately in quantities necessary for the particular organization in accordance with SB11-6.

Section II REPAIR PARTS AND SPECIAL TOOL LISTS

(1) Source Maintenance and Recoverability Code			(2) Federal Stock No.	(3) Description	(4) Unit of Issue	(5) Quantity Incorporated in Unit	(6) 15-Day Maintenance Allowance Per 100 Equipments		(7) Depot Maintenance Guide Per 100 Equipments	(8) Illustration	
(a) Source	(b) Maintenance Level	(c) Recover- ability					(a) Direct Support	(b) General Support		(a) Figure No.	(b) Item No.
B-4	P1	D	1240-907-6510	ADAPTER: (10513581)	1	2	12	5-12	7
	P	O	6135-120-1010	BATTERY, DRY: 1 5v, C size, type BA-42	1	5-7	3
	P1	F	5340-664-0095	BUSHING, RUBBER: syn, 0.150 id, 0.375 od, 0.150 lg (7649182)	4	1	0.1	*	12	5-4	3-H
	P1	F	6650-939-7174	CAP. ASSEMBLY: (8589920-2)	1	1	0.3	0.1	6	5-7	1
	P1	F	2640-507-9260	CAP, TIRE VALVE: (8200055)	4	1	0.2	0.2	12	5-2	4-A
	P1	F	1240-191-9213	CATCH: (10516029-3)	4	2	*	*	12	5-2	3
	P1	D	1240-907-6513	CELL ASSEMBLY , OPTICAL INSTRUMENT: (10513566)	1	2	6	5-11	2
	P1	D	6650-903-3882	CELL, OPTICAL ELEMENT: int thd, al, blk anodized fin 2-11/32-32UNS2, 0.188 lg (10513592)	1	2	6	5-9	4
	P1	F	5340-077-8727	CLIP, SPRING TENSION: (10516224)	4	1	*	*	8	5-3	13
	P1	F	6650-908-1983	CONNECTOR, PLUG ELECTRICAL: (10513612)	1	1	0.1	*	10	5-6	4
	P1	D	6650-907-9677	CONTACT, ELECTRICAL: brs, sil ctd, 2.280 dia, 0.562 o/a h (105 13574)	1	2	6	5-12	4
	P1	F	1240-818-7768	CONVERTER: (10553449)	1	1	0.3	0.1	10	5-7	3
	P1	F	5960-082-3326	ELECTRON TUBE: (MILE1/1049D)	1	2	0.1	0.1	40	5-8	3
	P1	D	1240-768-8724	FILTER, LIGHT: gl, red, 1.394 od, 0.128 thk (7688724)	1	2	4	5-14	5
	P1	F	5330-683-9573	GASKET: rd, syn rub., 0.370 id, 9/16 od, 0.062 thk (8574642)	4	1	*	*	40	5-2	6
	P1	F	5330-912-4852	GASKET: syn rub, 0.030 thk, 1-1/8 lg, 2-3/16 dia holes (10513561)	4	1	0.1	*	8	5-4	4
	P1	F	1240-069-2013	GASKET: syn rub-, 0.562 dia, 0.312 thk, 1.500o/alg, 4bolt holes(10516192)	12	1	*	*	12	5-3	8
	P1	O	6650-906-7941	HEAD ASSEMBLY, TANK PERISCOPE: (10513625)	1	1	0.3	3.2	12	1-1	..
	P1	F	6650-907-9678	INSULATION: soldered, 1.572 od, 1/2 lg, (10513604)	1	1	0.1	*	6	5-7	10
	P1	F	5970-548-9392	INSULATOR, DISK: plstc, 0.21 id, 1/16 thk, (7649181)	4	2	0.2	*	20	5-4	3-E
P1	F	5355-069-2012	KNOB: (10516194)	1	1	*	*	4	5-3	2	

B-5

(1) Source Maintenance and Recoverability Code			(2) Federal Stock No.	(3) Description	(4) Unit of Issue	(5) Quantity Incorporated In Unit	(6) 15-Day Maintenance Allowance Per 100 Equipments		(7) Depot Maintenance Guide Per 100 Equipments	(8) Illustration	
(a) Source	(b) Maintenance Level	(c) Recover- ability					(a) Direct Support	(b) General Support		(a) Figure No.	(b) Item No.
P1	D	..	1240-768-8722	LENS, OPTICAL INSTRUMENT: gl, 1.065 dia, 0.236 axial thk (7688722)	1	2	.	.	4	5-14	7
P1	D	..	6650-903-7225	LENS, OPTICAL INSTRUMENT: gl, 1.266 dia, 0.475 axial thk (10513553)	1	2	.	..	10	5-10	3
P1	D	..	1240-768-8718	LENS, OPTICAL INSTRUMENT: gl, doublet, 1.065 id, 0.512 axial thk (7688718)	1	2	4	5-14	9
P1	D	..	6650-904-4570	LENS, OPTICAL INSTRUMENT: gl, 1.999 dia, 0.4000 o/a axial thk, 0.250 edge thk (8579803)	1	2	6	5-13	2-D
P1	D	..	6650-902-9739	LENS, OPTICAL INSTRUMENT: gl, sect. A, 1.266 dia (10513554)	1	2	.	..	10	5-10	5
P1	D	..	6650-902-9740	LENS, OPTICAL INSTRUMENT: gl, sect. B, 1.266 dia (10513555)	1	2	.	.	16	5-10	7
P1	D	..	6650-902-9737	LENS, OPTICAL INSTRUMENT: gl, dbl convex, 1.395 dia 0.216 axial thk (8579805)	1	2	5	5-14	2
P1	D	..	1240-768-8725	LENS, OPTICAL INSTRUMENT: gl, objective, cem doublet, 1.394 od, 0.512 axial thk (7688725)	1	2	.	..	4	5-14	4
P1	D	..	6650-902-9736	LENS, OPTICAL INSTRUMENT: gl, plane concave, 1.900 dia, 0.100 axial thk (8579804)	1	2	.	..	6	5-13	2-E
P1	F	..	5310-2714644	NUT, PLAIN HEXAGON: cres, pass, fin., no. 6-32UNC-2B, 7164 thk, 5116 w (MS35649-64)	100	1	*	*	5	5-4	3-C
P1	D	..	5330-912-5829	PACKING, PREFORMED: syn rub., 2.234 id, 0.193 thk (10513593)	4	2	.	..	16	5-13	3
P1	D	..	5330-912-5830	PACKING, PREFORMED: syn rub., 2.364 id, 0.070 thk (10513594)	4	2	.	..	20	5-8	2-A
P1	D	..	5330-912-4842	PACKING, PREFORMED: syn rub., 1.364 id, 0.070 thk (10513595)	4	2	20	5-10	1
P1	D	..	5330-912-6256	PACKING, PREFORMED: syn rub., 1.614 id, 0.070 thk (10513596)	4	2	20	5-9	3-E
P1	D	..	5330-912-5814	PACKING, PREFORMED: syn rub., 1.864 id, 0.070 thk (10513597)	4	2	20	5-9	3-A

C1, TM 9-6650-222-35

(1) Source Maintenance and Recoverability Code			(2) Federal Stock No.	(3) Description	(4) Unit of Issue	(5) Quantity Incorporated In Unit	(6) 15-Day Maintenance Allowance Per 100 Equipments		(7) Depot Maintenance Guide Per 100 Equipments	(8) Illustration	
(a) Source	(b) Maintenance Level	(c) Recover- ability					(a) Direct Support	(b) General Support		(a) Figure No.	(b) Item No.
P1	F	..	1290-764-9178	PLUG CONTACT: hex. shld, brs, no. 6-32NC-2A X 1-1/16 lg o/a(7649178)	4	1	0.1		8	5-4	
P	F	..	5365-684-4401	PLUG, MACHINE THREAD: cres, 3/8-32NEF-2A, 0.270 lg (8574881)	4	1	*		8	5-2	5
P1	F	..	1240-077-1688	POWER SUPPLY, SOLID STATE: (10516158)	1	1	0.2	1.0	10	5-7	5
P1	D	..	1240-907-65 12	PRISM, OPTICAL INSTRUMENT, MOUNTED: (10513570)	1	1	..		10	5-5	3
P1	D	..	5650-904-0683	RETAINER, OPTICAL ELEMENT: al aly, blk anodized fin., dr hole dr, 2.046 flange dia, 0.820 lg o/a (105 13591)	1	2	..		6	5-9	3-A
P1	D	..	6650-903-3879	RETAINER, OPTICAL ELEMENT: al aly, blk anodized fin., dr hole dr, 1-3/4 hole dia, 1.925 shoulder dia, 1-31/32UNS-2A, 0.59 lg o/a (10513587)	1	2	..		6	5-9	3-F
P1	D	..	6650-903-3880	RETAINER, OPTICAL ELEMENT: al aly, blk anodized tin., dr hole dr, 0.967 hole dia, 0.267 recess dia, 1-3/8-32 thd size 1.20 lg o/a (10513579)	1	2	..		51	5-10	8

B-7

(1) Source, maintenance, and recoverability code			(2) Federal stock no.	(3) Description	(4) Unit of issue	(5) Quantity incorporated in unit	(6) 15-day maintenance allowance per 100 equipments		(7) Depot maintenance guide per 100 equipments	(8) Illustration	
(a) Source	(b) Maintenance level	(c) Recoverability					(a) Direct support	(b) General support		(a) Figure No.	(b) Item No.
P1	D	--	6650-902-7074	RETAINER, OPTICAL ELEMENT: al, blk anodized fin., 2 slots, 1.438-32UNS-2A, 1.290 hole dia, 0.160 lg o/a (10513558)	4	2	--	--	8	5-14	1
P1	D	--	6650-902-7075	RETAINER, OPTICAL ELEMENT: al, blk anodized fin., 2 slots, 1.125-32UNS-2A, 0.944 hole dia, 0.160 lg o/a (10513559)	4	2	--	--	8	5-14	6
P1	D	--	6650-902-7076	RETAINER, OPTICAL ELEMENT: al, blk anodized fin., 2 slots, 2.125-32UNS-2A, 0.944 hole dia, 0.160 lg o/a (10513560)	4	2	--	--	8	5-13	2-c
P1	F	--	1240-068-1657	RING, EXTERNALLY THREADED: al aly, anodized fin., 4 slots, 1-5/8-18UNEF-2A, 0.187 lg o/a (10516212)	1	1	*	*	4	5-7	7
P1	D	--	6650-902-8487	RING, EXTERNALLY THREADED: al aly, blk anodized fin., slot., 1-3/8-32UNS-2B, 0.170 lg o/a (10513577)	4	2	--	--	8	5-10	2
P1	D	--	6650-903-3876	RING, EXTERNALLY THREADED: al aly, blk anodized fin., slot. face, 1-9/16-32UNS-2B, 1.563 dia, 0.125 lg o/a (10513589)	4	2	--	--	8	5-8	2-F
P1	D	--	6650-904-5681	RING, EXTERNALLY THREADED: al aly, blk anodized fin., 2 slots, 1-11/16-32UNS-2B, 0.100 lg o/a (10513584)	4	2	--	--	4	5-9	3-C
P1	D	--	6650-904-5682	RING, INTERNALLY THREADED: al aly, 2 slots, 1.968-32UNS-2A, 0.100 lg o/a (10513588)	4	2	--	--	8	5-9	2
P1	F	--	5305-054-6650	SCREW, MACHINE : pan hd, cres, pass. fin., no. 632UNC-2A, 1/4 lg (MS51957-26)	100	4	*	*	100	5-1	1
P1	F	--	5305-054-6653	SCREW, MACHINE: pan hd, cres, pass. fin., no. 6-32UNC-2A, 7/16 lg (MS51957-29)	100	4	*	*	48	5-3	3
P1	D	--	5305-054-6654	SCREW, MACHINE: pan hd, cres, pass. fin., no. 6-32UNC-2A, 1/2 lg (MS5195730)	100	6	--	--	50	5-5	1
P1	F	--	5305-054-6669	SCREW, MACHINE : pan hd, cross recessed, cres, pass. fin., no. 8-32UNC-2A, 7/16 lg (MS51957-44)	100	1	*	*	10	5-3	10

(1) Source, maintenance, and recoverability code			(2) Federal stock no.	Description	(4) Unit of issue	(5) Quantity incorporated in unit	(6) 15-day maintenance allowance per 100 equipments		(7) Depot maintenance guide per 100 equipments	(8) Illustration	
(a) Source	(b) Maintenance level	(c) Recoverability					(a) Direct support	(b) General support		(a) Figure No.	(b) Item No.
P1	F	--	5305-054-6671	SCREW, MACHINE: pan hd, cres, pass. fin., no. 8-32UNC-2A, 5/8 lg (MS51957-46)	1	2	*	*	1	5-4	1
P1	D	--	5305-081-9735	SETSCREW: hdls, slot. dr, cone pt, cres, pass. fin., No. 8-64NF-2A, 0.094 lg (MS51059-16)	100	2	--	--	30	5-13	2-A
P1	D	--	5305-912-2693	SETSCREW: hdls, soc dr, dog pt., cres, pass. fin., no. 2-56UNC-3A, 0.160 lg (10513586)	12	4	--	--	14	5-9	1
P1	F	--	5305-800-7261	SETSCREW: hdls, soc dr, cup pt, cres, pass. fin., no. 4-40NC-3A, 0.125 lg (MS51021-9)	100	2	*	*	100	5-3	1
P1	D	--	5305-531-0137	SETSCREW: hdls, soc dr, cup pt, cres, pass. fin., no. 6-32NC-3A, 1/8 lg (MS51021-21)	100	6	--	--	50	5-6	2
P1	D	--	5305-551-0156	SETSCREW: hdls, soc dr, cup pt, cres, pass. fin., no. 8-32NC-3A, 3/16 lg (MS51021-31)	100	2	--	--	20	5-13	1
P1	D	--	5305-753-4451	SETSCREW: hdls, soc dr, cup pt, cres, pass. fin., no. 10-24NC-3A, 3/16 lg (MS51021-42)	100	4	--	--	40	5-12	1
P1	D	--	5305-068-1653	SETSCREW: hdls, soc dr, fp, cres, pass. fin., no. 2-64 UNF-3A, 1/16 lg (MS51031-7)	100	4	--	--	20	5-8	2-B
P1	D	--	5305-068-1655	SETSCREW: hdls, soc dr, half dog pt, cres, pass. fin., no. 6-32NC-3A, 1/4 lg (MS51045-20)	100	2	--	--	20	5-6	1
P1	D	--	5305-054-9250	SETSCREW: hdls, soc dr, half dog pt, cres, pass. fin., no. 6-32NC-3A, 0.500 lg (MS51045-23)	100	2	--	--	20	5-11	1
P1	D	--	5340-912-2671	SPRING, HELICAL COMPRESSION: cres, 0.018 dia wire, 0.108 od, 7/16 lg, 9 coil (10513572)	4	6	--	--	18	5-11	3
P1	D	--	5340-912-2672	SPRING, HELICAL COMPRESSION: cres, 0.18 dia wire, 0.108 od, 17/32 lg, 12 coil (10513573)	12	6	--	--	24	5-12	5
P1	F	--	5930-925-3631	SWITCH, ROTARY: (10516220)	1	1	*	*	8	5-3	9
P1	F	--	1240-535-7706	VALVE: inside air check (8200526)	4	1	0.5	0.5	12	5-2	4-B
P1	F	--	5310-043-1754	WASHER, LOCK: split, helical It, r lkg, cres, pass. fin., 0.239 od, 0.031 thk, no. 6 scr size (MS35337-79)	1	14	*	1	1	5-2	2

B-8

6-B

(1) Source Maintenance and Recoverability Code			(2) Federal Stock No.	(3) Description	(4) Unit of Issue	(5) Quantity Incorporated in Unit	(6) 15-Day Maintenance Allowance Per 100 Equipments		(7) Depot Maintenance Guide Per 100 Equipments	(8) Illustration	
(a) Source	(b) Maintenance Level	(c) Recover- ability					(a) Direct Support	(b) General Support		(a) Figure No.	(b) Item No.
P1	D	..	5310-042-9067	WASHER, LOCK: split, helical It, r lkg, cres, pass. fin., 0.280 od, 0.037 thk, no. 8 scr size (MS35337-80)	100	2	..		1	5-4	2
P1	F	..	5310-068-3260	WASHER, SPRING TENSION: stl, blk oxide tin., 0.890 id, 1.050 od, 0.011 thk 0.075 h o/a (10516207)	12	1	*	*	12	5-7	6
P1	F	..	5650-944-5150	HEADREST ASSEMBLY (10513437)	1	2	*	*	20	6-2	10
P1	O	..	5650-907-9680	GRIP: olive drab (8589822)	1	1	0.4	0.1	10	6-2	1
P1	F	HEADREST ASSEMBLY, OPTICAL INSTRUMENT (105 13490)	100	2	*	*	20	6-2	17
P1	F	..	5305-905-3050	SCREW, MACHINE: flat, csk, cross recessed, cres, pass. tin., no. 10-24UNC-2A, 7/8 lg, (MSS1959-66)	100	1	*	*	10	6-2	14
P1	F	..	5340-912-2670	SETSCREW: hdls, half dog pt, cm, pass. tin., no. 6-40UNF-3A, 3/16 C (MS51047-15)	4	1	*	*	8	6-2	12
P1	F	..	6650-908-1984	SPRING, HELICAL COMPRESSION: 0.036 dia wire, 0.316 od, 1-1/2 lg, 14 coil (10513486)	1	1	*	*	5	6-2	15
P1	R		6650-907-9679	SUPPORT, HEADREST: (10511396) EQUIPMENT FOR PERISCOPE XM48	1	1	*	*	5	6-1	..
				HEADREST ASSEMBLY OPTICAL INSTRUMENT: (10513437)							

PART NUMBER INDEX

1	2	3 Illustration		4	1	2	3 Illustration		4
Part Number	Federal Stock No	A Figure NO.	B Item NO	Total Quantity	Part Number	Federal Stock No.	A Figure No.	B Item No.	Total Quantity
7649178	1290-764-9178	54	3-J	1	10513591	6650-904-0683	5-9	3-A	2
7649181	5970-548-9392	5-4	3-E	2	10513592	6650-903-3882	5-9	4	2
7649182	5340-664-0095	5-4	3-H	1	10513593	5330-912-5829	5-13	3	2
7688718	1240-768-8718	5-4	9	2	10513594	5330-912-5830	5-8	2-A	2
7688722	1240-768-8722	5-14	7	2	10513595	5330-912-4842	5-10	1	2
7688724	1240-768-8724	5-14	5	2	10513596	5330-912-6256	5-9	3-E	2
7688725	1240-768-8725	5-14	4	2	10513597	5330-912-5814	5-9	3-A	2
8200055	2640-507-9260	5-2	4-A	1	10513604	6650-907-9678	5-7	10	1
8200526	1240-535-7706	5-2	4-B	1	10513612	6650-908-1983	5-6	4	1
8574642	6330-683-9573	5-2	6	1	10513625	6650-906-7941	1-1		1
8574881	5365-684-4401	5-2	5	1	10516029-3	1240-191-9213	5-2	3	2
8579803	6650-904-4570	5-13	2-D	2	10516158	1240-077-1688	5-7	5	1
8579804	6650-902-9736	5-13	2-E	2	10516192	1740-069-2013	5-3	8	1
8579805	6650-902-9737	5-14	2	2	10516194	5355-069-2012	5-3	2	1
8589822	6650-944-5150	6-2	10	2	10516207	5310-068-3260	5-7	6	1
8589920-2	6650-939-7174	5-7	1	1	10516212	1240-068-1657	5-7	7	1
10511396	6650-908-1984	6-2	15	1	10516220	5930-925-3631	5-3	9	1
10513437	6650-907-9679	6-1	..	1	10516224	5340-077-8727	5-3	13	1
10513586	5340-912-2670	6-2	12	1	10553449	1240-878-7768	5-7	3	1
10513490	6650-907-9680	6-2	1	1	BA-42	6135-120-1010	5-7	3	..
10513553	6650-903-7225	5-10	3	2	MIL-E-1/1049D	5960-082-3326	5-8	3	2
10513554	6650-902-9739	5-10	5	2	MS35337-79	5310-043-1754	5-2	2	14
1051-3555	6650-902-9740	5-10	7	2	MS35337-80	5310-042-9067	5-4	2	1
10513558	6650-902-7074	5-14	1	2	MS35649-64	5310-271-4644	5-4	3-C	1
10513559	6650-902-7075	5-14	6	2	MS51021-9	5305-800-7261	5-3	1	2
10513560	6650-902-7076	5-13	2-C	2	MS51021-21	5305-531-0137	5-6	2	6
10513561	5330-912-4852	5-4	4	1	MS51021-31	5305-551-0156	5-13	1	2
10513566	1240-907-6513	5-11	2	2	MS51021-42	5305-753-4451	5-12	1	4
10513570	1240-9076512	5-5	3	1	MS51031-7	5305-068-1653	5-8	2-B	4
10513572	5340-912-2671	5-11	3	6	MS51045-20	5305-068-1655	5-6	1	2
10513573	5340-912-2672	5-12	5	6	MS51045-23	5305-054-9250	5-11	1	2
10513574	6650-907-9677	5-12	4	2	MS51047-15	5305-905-3050	6-2	14	1
10513577	6650-902-8487	5-10	2	2	MS1059-16	5305-081-9735	5-13	2-A	2
10513579	6650-903-3880	5-10	8	2	MS51957-26	5305-054-6650	5-1	1	4
10513581	1240-907-6510	5-12	7	2	MS51957-29	5305-054-6653	5-3	3	4
10513584	6650-904-5681	5-9	3-C	2	MS51957-30	5305-054-6654	5-5	1	6
10513586	5305-912-2693	5-9	1	4	MS51957-44	5305-054-6669	5-3	10	1
10513587	6650-903-3879	5-9	3-F	2	MS51957-46	5305-054-6671	5-4	1	2
10513588	6650-904-5682	5-9	2	2	MS51959-66	..	6-2	17	2
10513589	6650-903-3876	5-8	2-F						

B-10

STOCK NUMBER INDEX

1	2	3 Illustration		4	1	2	3 Illustration		4
Part Number	Federal Stock No.	A Figure No.	B Item No.	Total Quantity	Part Number	Federal Stock No.	A Figure NO.	B Item NO.	Total Quantity
1240-068-1657	10516212	5-7		1	5330-912-5830	10513594	5-8		2-A
1240-069-2013	10516192	5-3		8	5330-912-6256	10513596	5-9		3-E
1240-077-1688	10516158	5-7		5	5340-077-8727	10516224	5-3		13
1240-191-9213	10516029-3	5-2		3	5340-664-0095	7649182	5-4		3-H
1240-535-7706	8200526	5-2	4-B	4-B	5340-912-2610	10513486	6-2		12
1240-768-8718	7688718	5-4	3-J	3-J	5340-912-2671	10513512	5-11		3
1240-768-8722	7688722	5-14		1	5340-912-2672	10513573	5-12		5
1240-768-8724	7688724	5-14		5	5355-069-2012	10516194	5-3		2
1240-768-8725	7688725	5-14		4	5365-684-4401	8514881	5-2		5
1240-878-7768	10553449	5-7		3	5930-925-3631	10516220	5-3		9
1240-9076510	10513581	5-11		1	5960-062-3326	MIL-E-1/1049D	5-8		3
1240-9074512	10513570	5-5		3	5970-548-9292	1649181	5-4		3-E
1240-907-6513	10513566	5-11		2	6135-120-1010	BA-42	5-1		3
1290-764-9175	7649178	5-4	3-J	3-J	6650-902-1014	10513558	5-14		1
2640-507-9260	8200055	5-2	4-A	4-A	6650-902-1015	10513559	5-14		6
5305-054-6650	MS51957-26	5-1		1	6650-902-1016	10513560	5-13		2-C
5305-054-6653	MS51917-29	5-3		3	6650-902-8487	10513577	5-10		2
5306-054-6654	MS51957-30	5-5		1	6650-902-9736	9519804	5-13		2-E
5305-0546669	MS5195744	5-3		10	6650-902-9131	8519805	5-14		2
5305-0546671	MS51957-46	54		1	6650-902-9139	10513554	5-10		5
5305-054-9250	MS51045-23	5-11		1	6650-902-9140	10513555	5-10		1
5305-068-1653	MS51031-7	5-8	2-B	2-B	6650-903-3876	10513589	5-8		2-F
5305-068-1655	MS51045-20	5-6		1	6650-903-3879	10513587	5-9		3-F
5305-081-9735	MS51069-16	5-1:	2-A	2-A	6650-903-3880	10513519	5-10		8
5305-531-137	MS51021-21	5-6		2	6650-903-3882	10513592	5-9		4
5305-551-0156	MS51021-31	5-1:		1	6650-903-1225	10513553	5-10		3
5305-753-4451	MS50021-42	5-1:		1	6650-904-0683	10513591	5-9		3-A
5305-800-7261	MS51021-9	5-3		1	6650-904-4510	8519803	5-13		2-D
5305-905-3050	MS51047-15	6-2		14	6650-904-5681	10513584	5-9		3-C
5305-912-2693	10513586	5-9		1	6650-904-5682	10513588	5-9		2
5310-042-9067	MS35337-80	5-4		2	6650-906-7941	10513625	1-1		
5310-043-1754	MS35337-79	5-2		2	6650-901-9671	19513514	5-12		4
5310-068-3260	10516207	5-7		6	6650-901-9618	10513604	5-1		10
5310-271-4644	MS35649-64	5-4	3-C	3-C	6650-901-9679	10513431	6-1		.
5330-683-9573	9574642	5-2		6	6650-901-9680	10513490	6-2		1
5310-9124842	10513595	5-10		1	6650-808-1983	10513612	5-6		4
5330-9124852	10513561	5-4		4	6650-908-1984	10511396	6-2		15
5330-912-5814	10513597	5-9	3-A	3-A	6650-939-7174	8589920-2	5-1		1
5330-912-5829	10513593	5-1:		3	6650-944-5150	8589822	6-2		10

B-11



INDEX

	Paragraph	Page
Accident reports (See Report of accidents)		
Adapter 4931-508-5453 -----	2-2,5-13	2-1,5-10
.Adjustment and test (See Test and adjustment)		
Armored Reconnaissance Airborne Assault Vehicle: XM551 -----	1-1b	1-1
Authorized forms -----	1-4	1-1
Cap assembly and power supplies (See Also power supplies and cap assembly) :		
Inspection -----	5-11b	5-5
Installation-----	5-11c	5-6
Removal-----	5-11a	5-5
Catch :		
Inspection-----	5-7b	5-1
Installation-----	5-7	5-1
Removal-----	5-7a	5-1
Comments, technical manual -----	1-2	1-1
Data -----	1-6	1-2
Depot Maintenance Work Requirements (DMWR) -----	1-1a	1-1
Description :		
Body Assembly -----	1-5	1-2
General-----	15a	1-1
Headassembly-----	1-5c	1-1
Optical scheme -----	1-56	1-1
Electrontube-----	5-12	5-7
Equipment Improvement Recommendations (EIR) -----	1-4c	1-1
Equipment issued with periscope:		
General-----	6-1a	6-1
Forms, authorized (See Authorized forms)		
Forms, records, and reports-----	1-4	1-1
Gasket (See Machine thread plug and gasket)		
General Maintenance Procedures -----	5-3	5-1
Gun, injection, hydraulic 4931-508-5428 -----	2-2,5-13	2-1,5-10
Headrest assembly:		
Inspection-----	6-3	6-2
Troubleshooting -----	6-4	6-3
Headrest retaining plunger:		
Inspection-----	6-76	6-5
Installation-----	6-7c	6-5
Removal-----	6-7a	6-5
Headrest support:		
Inspection-----	6-5b	6-3
Installation-----	6-5c	6-3
Removal-----	6-5a	6-3
Housing retainer plunger:		
Inspection-----	6-6b	6-5
Installation-----	6-6c	6-5
Removal-----	6-6a	6-3

	Paragraph	Page
Hose, assembly 4931-508-5546 -----	2-2,5-13	2-1,5-10
Hose, assembly 4931-561-9713 -----	2-2,5-13	2-1,5-10
Inspection :		
P u r p o s e -----	3-2	3-1
S c o p e -----	3-1	3-1
Inspection, shop :		
G e n e r a l -----	3-9	3-2
I n i t i a l -----	3-10	3-2
S e a l i n g -----	3-11	3-2
Inspection, optical components (shop) :		
B o d y a s s e m b l y -----	3-12b	3-2
H e a d a s s e m b l y -----	3-12a	3-2
Inspection, using position :		
E l e c t r i c a l c o m p o n e n t s -----	3-8	3-2
G e n e r a l -----	3-6	3-1
M o d i f i c a t i o n w o r k o r d e r (MWO) -----	3-5	3-1
O p t i c a l c o m p o n e n t s -----	3-1	3-2
S e r v i c e a b i l i t y d e t e r m i n a t i o n -----	3-3	3-1
U s i n g p o s i t i o n -----	3-4	3-1
Machine thread plug and gasket:		
I n s p e c t i o n -----	5-9b	5-3
I n s t a l l a t i o n -----	5-9c	5-3
R e m o v a l -----	5-9a	5-2
Maintenance allocation and parts -----	1-3	1-1
Maintenance Procedures, General (See General maintenance procedures)		
Modification Work Orders (MWO) -----	3-5	3-1
Packaging and processing (See Processing and packaging)		
Parts, maintenance allocation (See Maintenance allocation and parts)		
Power supplies and cap assembly (See Cap assembly and power supplies)		
Processing and packaging:		
F i n a l p a c k a g i n g -----	7-3	7-1
G e n e r a l -----	7-1	7-1
H e a d r e s t a s s e m b l y -----	1-4	7-1
O p t i c a l c o m p o n e n t s -----	7-2	7-1
Records, reports, and forms (See Forms, records, and reports)		
Regulator, helium pressure 1240-558-0922 -----	2-2,5-13	2-1,5-10
Repair (See Also specific items) :		
C l e a n i n g -----	5-5	5-1
G e n e r a l -----	5-6	5-1
G e n e r a l m a i n t e n a n c e p r o c e d u r e s -----	5-3	5-1
P a i n t i n g -----	5-4	3-1
P a r t s r e p l a c e m e n t -----	5-2	5-1
S c o p e -----	5-1	5-1
Report of accidents -----	1-4b	1-1
Reports, records, and forms (See Forms, records, and reports)		
Retaining plunger, headrest (See Headrest retaining plunger)		
Retainer plunger, housing (See Housing retainer plunger)		
Shop inspection (See Inspection, shop)		
Size -----	1-6c	1-2
Switch :		
I n s p e c t i o n -----	5-10b	5-5
I n s t a l l a t i o n -----	5-10c	5-5
R e m o v a l -----	5-10a	5-5
Tables :		
S p e c i a l t o o l s a n d e q u i p m e n t (Table 2-1)-----	2-2	2-1

	Paragraph	Page
Troubleshooting (Table4-1) -----	4-4	4-1
Troubleshooting, headrest assembly 6650-907-9679 (Table 6-1) -----	6-4	6-3
Tank, nitrogen 6830-264-908 -----	2-2,5-13	2-1,5-10
Test and adjustment: -----	5-13	5-10
Purging and charging body assembly -----	5-13a	5-10
Tools and equipment (See Also specific items) :		
Common tools and equipment-----	2-1	2-1
Special tools and equipment -----	2-2	2-1
Troubleshooting:		
General-----	4-2	4-1
Purpose-----	4-1	4-1
Tube, electron (See Electron tube)		
Valve assembly :		
Assembly-----	5-8d	5-1
Disassembly-----	5-8b	5-1
Inspection-----	5-8c	5-1
Installation-----	5-8e	5-2
Cleaning-----	5-8a	5-1
Weight -----	1-6b	1-2

TM 9-6650-222-35

By Order of the Secretary of the Army:

Official:

J. C. LAMBERT,
*Major General, United States Army,
The Adjutant General*

HAROLD K. JOHNSON,
*General, United States Army,
Chief of Staff*

Distribution:

To be distributed in accordance with DA Form 12-41 requirements for Direct and General Support Maintenance for Periscope.

*U.S. GOVERNMENT PRINTING OFFICE: 1966--204435/2446

TM 9-6650-222-35 PERISCOPE, TANK: XM48 (6650-762-9336)-1966